

# FC Power/DI/DO Module

## Basic Installation Instructions v1.5

Dear users, please go through the instructions in detail before the installation. Also, please hand the manual to the actual operator of the machine and preserve it properly.

CNC controllers are precision electronic devices. For the safety of both operators and the machine, please ensure all installations, tests, and adjustments are operated by professional personnel. For the description with “DANGER”, “WARNING” and “CAUTION” in the manual, please read them in detail. If there are any concerns, please contact our branches in your region. Our professionals are glad to be at your service.

The following are the guidelines you should comply with before finishing reading the complete manual:

- The installing environment should be indoor and without water vapor, corrosive or flammable gas.
- Implement the wirings according to the wiring diagram.
- The grounding must be strictly implemented and follow the current National Electrical Code. (References: NFPA 70: National Electrical Code,2005 Ed.)
- Do not modify the wirings while the device is powered up.

### 1. Safety Precautions

Please pay extra attention to the instructions below while operating the product.

- Please install the controller according to the manual or it might cause damage to the equipment.
- Do not operate the product in places exposed to water vapor, corrosive, or flammable gases. It might cause damage to the device, electric shocks, fire, or explosion.
- Do not install the product at a temperature exceeding the specified range. It might cause device damage or malfunctioning.
- The controller series is designed to control the motor of the machine tool and manage the IO control. Do not touch the internal circuits or components while the controller is powered up. It might cause electric shock or device damage.
- The internal circuit board of the driver contains CMOS ICs, which are vulnerable to static electricity. Do not touch the circuit board with your hands before taking any precautions.
- The product has been tested and found to comply with the limits for a KC Class A Commercial equipment) digital device. It was designed for use in commercial and industrial environments instead of households.
- Do not apply the product to machines that might lead to casualties, device damage, or system shut down.



	<ul style="list-style-type: none"> <li>■ Please cut off all the external loads when powering up the controller for the first time. The built-in testing PLC program may start the motor immediately after power-up, which might be dangerous for the staff around.</li> <li>■ The controller is a precision instrument. Please prevent non-maintenance staff or non-professional electronic control personnel from disassembling the device.</li> <li>■ Please separate the communication cable of the driver from all the other motor and power cables with individual wiring ducks to prevent the controller from malfunction caused by large noise interference.</li> <li>■ Please apply the correct ground loop to prevent errors from the controller.</li> </ul>
	<ul style="list-style-type: none"> <li>■ The CNC controller adopts a microcomputer design. Please install the controller in a safe area and keep the area clean. Please keep iron shavings, wires, water, corrosive gas, and liquid from the driver to avoid malfunction.</li> <li>■ Storage temperature range: -20°C~60°C Storage relative humidity range: 0% to 90% and without condensation.</li> <li>■ Operating temperature range: -10°C~55°C Please reserve at least 50mm in width for ventilation and heat dissipation.</li> <li>■ The grounding of the controller and machine tool system is necessary for leakage protection and prevention of lightning strikes. Please ensure the driver and the machine tool system are grounded properly before installing.</li> <li>■ The rated voltage of the controller power system should not exceed 24V±20%. If the operating environment provides an unstable voltage source, please apply a voltage stabilizer so that the controller can function properly.</li> <li>■ Please turn off the power before plugging/unplugging the cables or modifying the wirings to prevent electric shocks or damage to the driver.</li> <li>■ Please ensure all the terminals are in the correct positions while wiring to prevent the driver from damage caused by wiring mistakes.</li> <li>■ Do not touch the terminals within 10 minutes after cutting off the power in case the residual voltage might cause electric shocks.</li> <li>■ Do not touch the panel with sharp objects or it might cause malfunction due to depression.</li> <li>■ To ensure communication quality, the length of USB extension cords in use shall not exceed five meters. Besides, do not charge or supply power via the USB port; otherwise, it may cause controller malfunction.</li> </ul>

### 2. Interface Specifications

(Front View: Power Module)

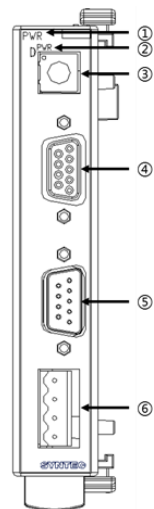

Number	Module Name	Abbreviation of the module name (Power Module=PWR)
1	Module Name	Abbreviation of the module name (Power Module=PWR)
2	Power Indicator	Indicate the power condition (Green light)
3	Rotary DIP Switch	Set the number of the function module. The power module site number of each function module cannot repeat.
4	SRI Port (D-sub female terminal)	Connect to the SRI interface of the Syntec Controller
5	SRI Port (D-sub male terminal)	Connect to the SRI interface of other FC modules
6	Power Input Terminal	24V Power Input (Current need: 1A)

(DI/DO Module Front View)

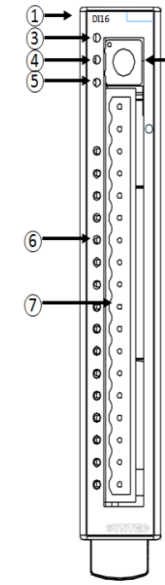

Number	Module Name	Module name abbreviation (DI16/DO16)
1	Module Name	Module name abbreviation (DI16/DO16)
2	Rotary DIP Switch	Set the number of the function module.
3	Power Indicator Light	Indicate the power condition(Green light)
4	Operating Indicator Light	Indicate the operating condition (Yellow light)
5	Abnormal Indicator Light	Indicate the abnormal condition (Red light)
6	Signal Indicator Light	The indicator light turns yellow when the I/O point is activated.
7	Input/Output Terminal	I/O terminal (Refer to 3-1: Terminal Definition)

(Side View)

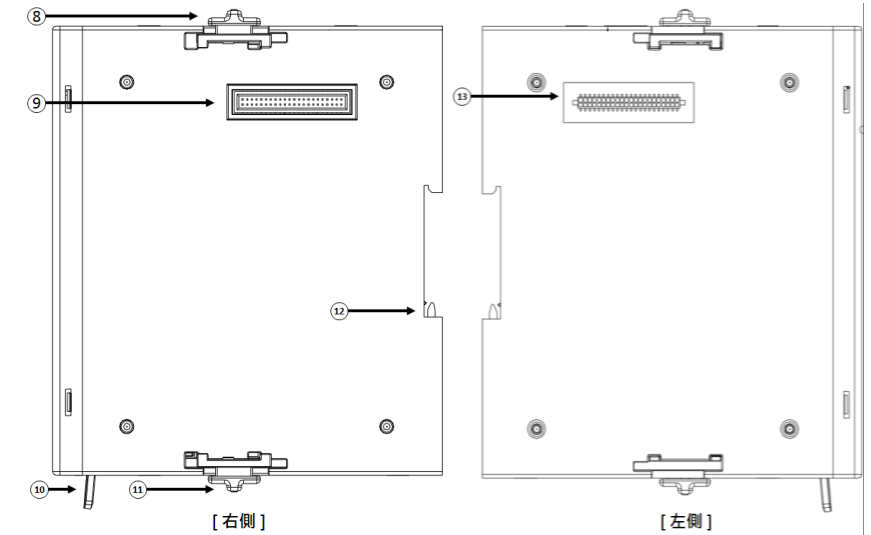

8	Upper Fastener	Connect to the upper fasteners of other FC function modules
9	Internal Communication Port (Right)	Connect to other FC function modules for communication
10	Slide Tenon Batch	Control the slide tenon
11	Lower Fastener	Connect to the lower fastener of other FC function modules
12	Slide Tenon	Fix the tenon on the slide
13	Internal Communication Port (Left)	Communicate with other FC modules, PWR module does not have this function

### 3. External Dimension (Unit: mm)

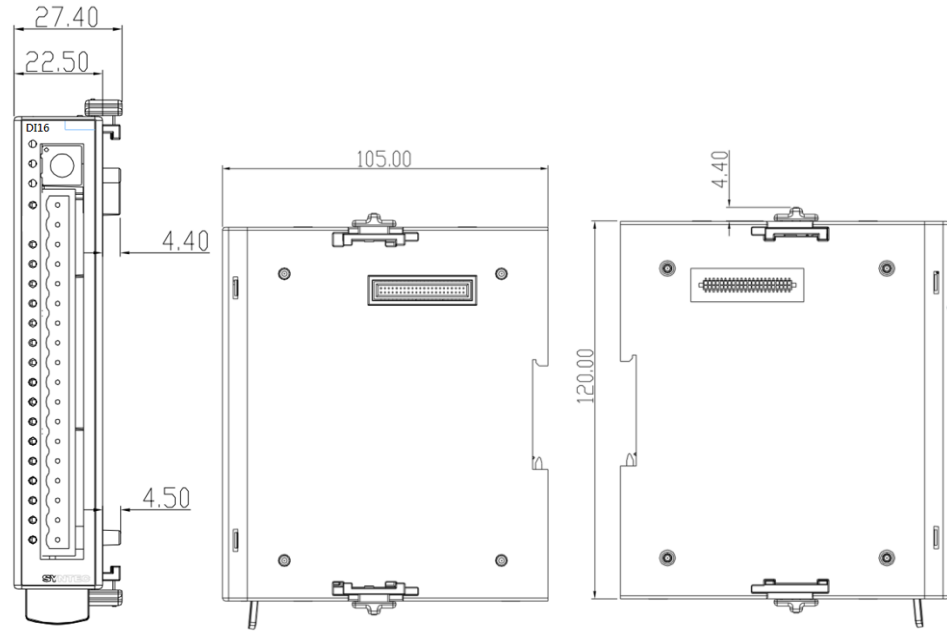

### 4. Basic Wiring Diagram

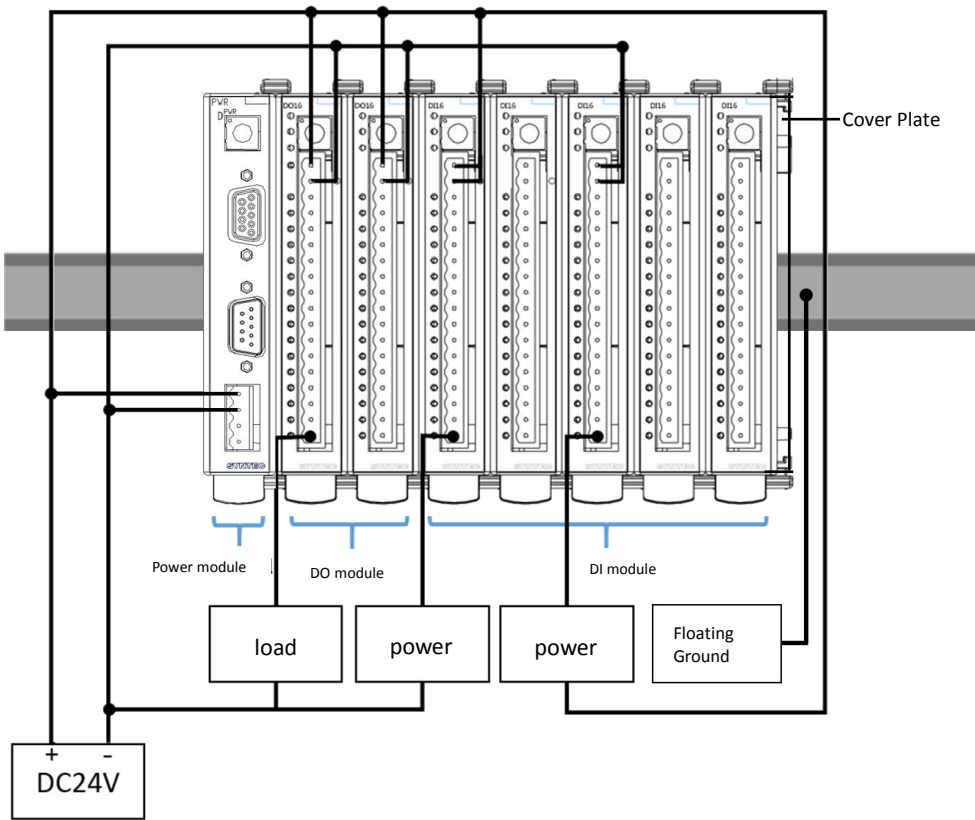

※Note:  
Please ensure to cover  
with the cover plate.

### 5. Interface Configurations

Please notice the value and polarities of voltages.

Power Module Terminal Arrangement

#### ● DC 24V Arrangement

24V 電源輸入	PIN	SIGNAL
1	1	24V
	2	GND
	3	--
4	4	FG

#### ● DI Module Terminal Arrangement

編號	接腳名稱
1	COM
2	COM
3	輸入訊號 1
4	輸入訊號 2
5	輸入訊號 3
6	輸入訊號 4
7	輸入訊號 5
8	輸入訊號 6
9	輸入訊號 7
10	輸入訊號 8
11	輸入訊號 9
12	輸入訊號 10
13	輸入訊號 11
14	輸入訊號 12
15	輸入訊號 13
16	輸入訊號 14
17	輸入訊號 15
18	輸入訊號 16

#### 6. Interface Circuit

##### ● DO16-PNP Interface

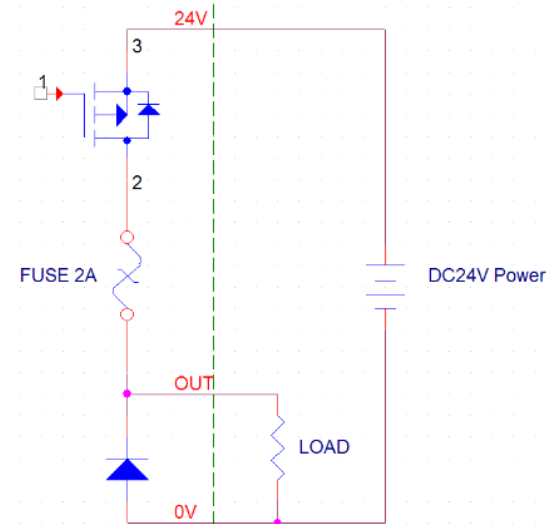

#### ● SRI Arrangement

SRI 母頭	SRI 公頭	PIN	SIGNAL
		1	SRI_D+
		2	SRI_D-
		3	--
		4	--
		5	GND
		6	--
		7	--
		8	--
		9	--

#### ● DO Module Terminal Arrangement

※Output current of per O point (Max.): 0.5A

編號	接腳名稱
1	24V
2	0V
3	輸出訊號 1
4	輸出訊號 2
5	輸出訊號 3
6	輸出訊號 4
7	輸出訊號 5
8	輸出訊號 6
9	輸出訊號 7
10	輸出訊號 8
11	輸出訊號 9
12	輸出訊號 10
13	輸出訊號 11
14	輸出訊號 12
15	輸出訊號 13
16	輸出訊號 14
17	輸出訊號 15
18	輸出訊號 16

#### ● DI16-PNP Interface

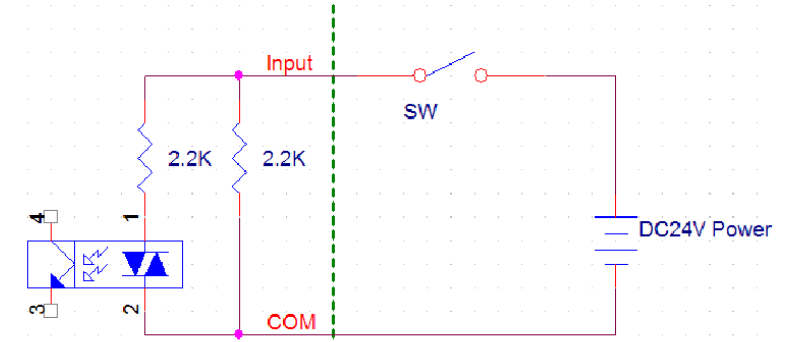

#### ● DI16-NPN Interface

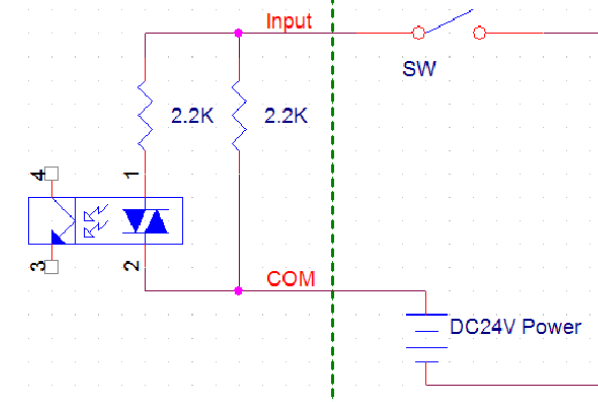

### 7. Wiring Notifications

- Please connect the ground wire to class-3 (under 100Ω). Poor grounding might cause signal errors, electric shock, or fire.
- When using a solenoid valve or other inductive loads, please apply an arc extinguisher or an RC varistor to ensure the life of the contact points. Advantages of the arc extinguisher:
  - 1) Extend the life of electrical contacts.
  - 2) Reduce the sparks from the contact points.
  - 3) Restrain the impulse voltage.
  - 4) Prevent the inductive loads from interferences caused by back EMF
- If the servo line in use is not a standard Syntec cable, please verify all the terminals are connected properly before power-on. Wrong wirings will lead to controller output command errors and malfunctioning.
- Do not connect other cables to extend the original length. It might cause signal errors or malfunction.
- The external 24V power supply used in wiring should be certificated and protective to avoid the malfunction caused by wiring mistakes. (Recommendation standard : fulfill requirements of both EN60950 or UL1950)
- Please crimp or weld the wire connections while doing the wirings.
- In case of the use of Ethernet, to prevent internet congestion and noise, the CAT5e or CAT6 cable is recommended.
- Do not use counterfeit terminal strips. Those terminal strips cannot provide overall protection for the system. The quality is also not guaranteed and tends to cause electrical control problems of the machine tools.

- To avoid noise interference, it is recommended to use Syntec standard SRI cables to connect to Syntec controllers. As for the cables connecting to other FC modules, shielded twisted pairs are recommended.
- Grounding Directions:
  - 1) The guide rail of FC Controller sets must be grounded.
  - 2) The length of grounding wires should comply with the electrical equipment regulations; the shorter the better.
  - 3) The grounding wire of the driver should be grounded separately with high-current loads such as electric welders or high-frequency motors.
  - 4) Please refer to the pictures below when the controller is grounded with multiple electrical control devices. Do not make it a loop.

(a) O

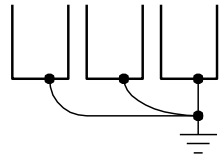

(b) O

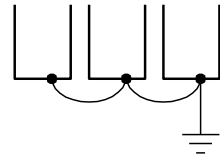

(c) X

