

SMD-22B-2020-00 Driver

Basic Installation Instructions V1.1

Dear users, please go through the instructions in detail before the installation. Also, please hand the manual to the actual operator of the machine and preserve it properly.

Drivers are precision electronic devices. For the safety of both operators and the machine, please ensure all installations, tests and adjustments are operated by professional personnel. For the description with "DANGER", "WARNING" and "CAUTION" in the manual, please read them in detail. If there are any concerns, please contact our branches in your region. Our professionals are glad to be at your service. The following are the guidelines you should comply with before finishing reading the complete manual:

- The installing environment should be indoor and without water vapor, corrosive or flammable gas.
- Implement the wirings according to the wiring diagram.
- The grounding must be strictly implemented and follow the current National Electrical Code. (References: NFPA 70: National Electrical Code, 2005 Ed.)
- Do not modify the wirings while the device is powered up.

1. Safety Precautions

請使用者在操作本產品時，特別留意以下各事項	
	<ul style="list-style-type: none"> ■ Install the driver according to the instructions in the manual or it might cause damage to the equipment. ■ Do not operate the product in places exposed to water vapor, corrosive or flammable gases. It might cause damage to the device, electric shocks, fire or explosion. ■ Do not install the product at a temperature exceeding the specified range. It might cause device damage or malfunctioning. ■ The driver series are designed to control the motors. Do not touch the internal circuits or parts while the driver is powered up. ■ The internal circuit board of the driver contains CMOS ICs, which are vulnerable to static electricity. Do not touch the circuit board with your hands before taking any precautions. ■ The product has been certified by EN 61800-5-1/EN 61800-3. It is for use in industrial environments. ■ Do not apply the product to machines that might lead to casualties, device damage or system shut down.
	<ul style="list-style-type: none"> ■ Please cut off all the external device loads when powering up the driver for the first time in case the built-in testing program starts running the motor immediately after power input. It may be dangerous for the operators around. ■ The driver is a precision instrument. Please prevent non-maintenance staff or non-professional electronic control personnel from disassembling the device. ■ Please apply the correct ground loop to prevent signal errors. ■ Please separate the communication cable of the driver from all the other motor and power cables with individual wiring ducks to prevent the controller from malfunction caused by large noise interference.
	<ul style="list-style-type: none"> ■ The driver adopts microcomputer design. Please install the driver in a safe area and keep the area clean. Please keep iron shavings, wires, water, corrosive gas and liquid from the driver to avoid malfunction. ■ Please reserve at least 50mm in width for ventilation and heat dissipation. ■ The grounding of the driver and machine tool system is necessary for leakage protection and prevention of lightning strikes. Please ensure the driver and the machine tool system are grounded properly before installing. ■ The power system of the driver should meet the rated voltage. If the operating environment provides an unstable voltage source, please apply a voltage stabilizer so that the driver can function properly. ■ Please turn off the power before plugging/unplugging the cables or modifying the wirings to prevent electric shocks or damage to the driver. ■ Please make sure all the terminals are in the correct positions while wiring to prevent the driver from damage caused by wiring mistakes. ■ Do not touch the terminals within 10 minutes after cutting off the power in case that the residual voltage might cause electric shocks ■ Unload the driver after the driver is powered off after 30 minutes.

2. Installation Notifications

- The leakage current of an all-in-one driver is usually over 3.5mA. In accordance with EN 61800 5-1, fixed installation is required.
- The direction of the installation must comply with the regulations, otherwise it will cause servo failure.
- When installing the driver, the air intake and vent holes should not be sealed, and the driver should not be tipped; otherwise it will cause malfunctions.
- Do not install the driver near flammable materials.
- Ensure every mounting hole is locked up when fixing the driver.
- Ensure the installation surface can support the weight of the driver.

3. Driver Interface Instructions

(Top view)

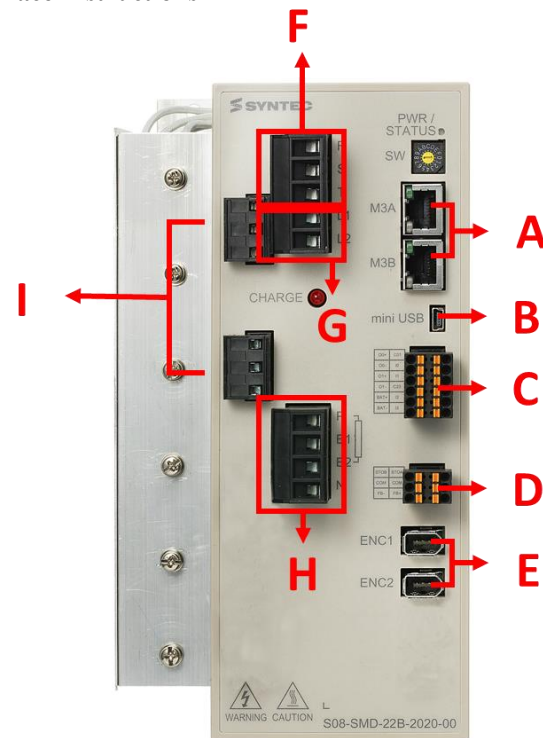

Driver Function		
A	M3 Serial Communication Port	Connect to the host controller and the next driver, 100Mbps serial communication
B	Mini USB Port	Connect to personal computer.
C	I/O Signal Port External Battery Port	Connect to I/O equipment (i.e. the emergency stop, indicator lights, etc.) Connect to power supplies of absolute encoders.
D	STO Signal Port	STO interface; 2 sets of safety inputs and a set of safety function feedback.
E	Encoder Feedback	From top to bottom are the first port to the second. The first to the second ports connect to motor encoders.
F	External Power Supply	Connect to 220V~230V three-phase power (RST).
G	Control Power	If there are safety requirements, the controlled source can be independently supplied from L1 & L2 and connect to single-phase AC 220V. The input voltage must be the same as RST.
H	Regenerative Resistor	Two connection methods, optional: a) Connect the external regenerative resistor to P & B2 b) The built-in brake is to short circuit B1 and B2
I	Machine Power Supply	Connect to motor and supply power (UVW)

4. Controller Specifications (Unit: mm)

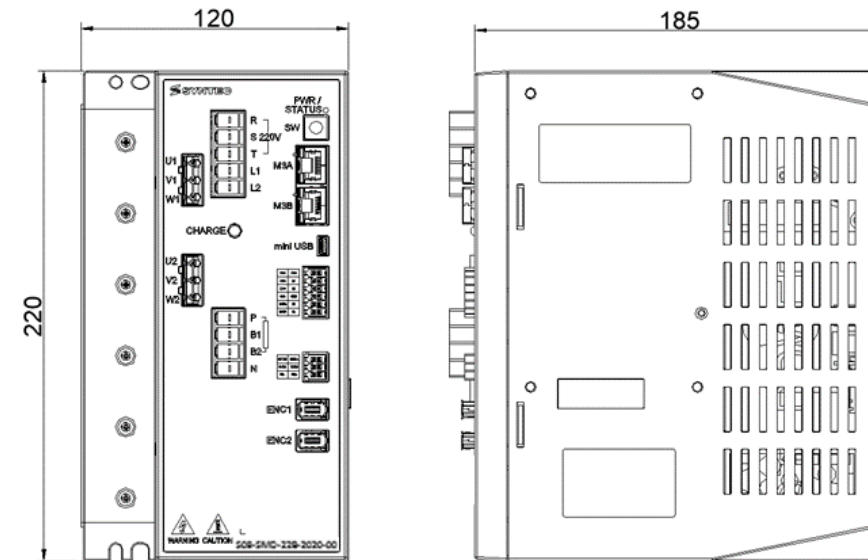

5. Installation Specifications (Unit: mm)

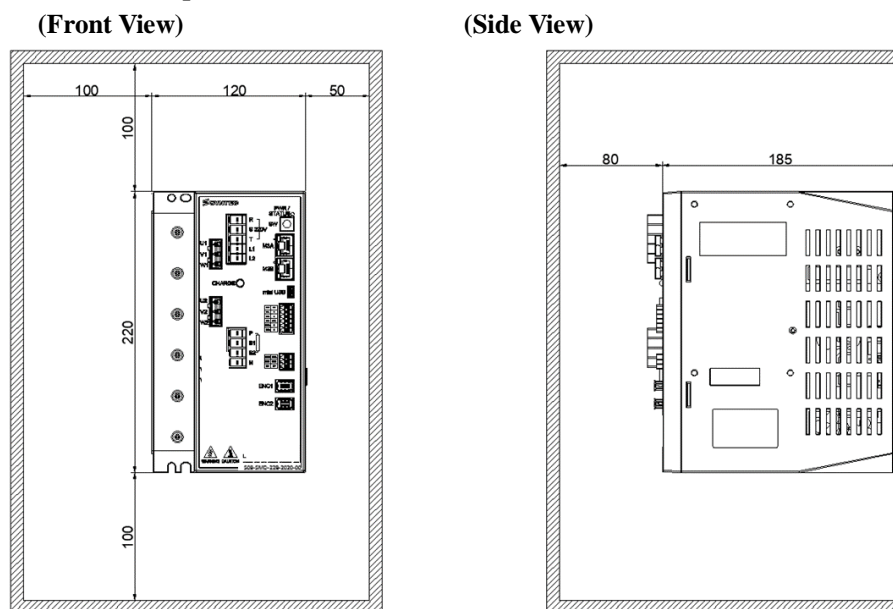

6. Mounting Hole Specifications (Unit: mm) Please install with M5 screws.

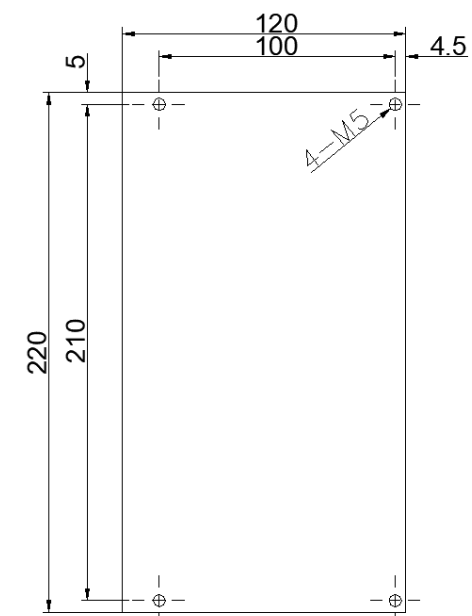

7. Basic Wiring Diagram

- Please Confirm whether the wiring of the U, V, W terminals output to the motor is correct, otherwise it may cause reversal or abnormality, and the encoder must be adjusted again.
- In case the use of independent controlled source, please connect the sources (L1, L2) of the control plate to either of the three RST terminals before the magnetic contactor (MC).
- The default settings of B1 and B2 are short circuit with built-in braking resistors. If the processing requires a high load factor, it is recommended removing the short circuit wiring and apply an external high wattage braking resistor between P and B2.

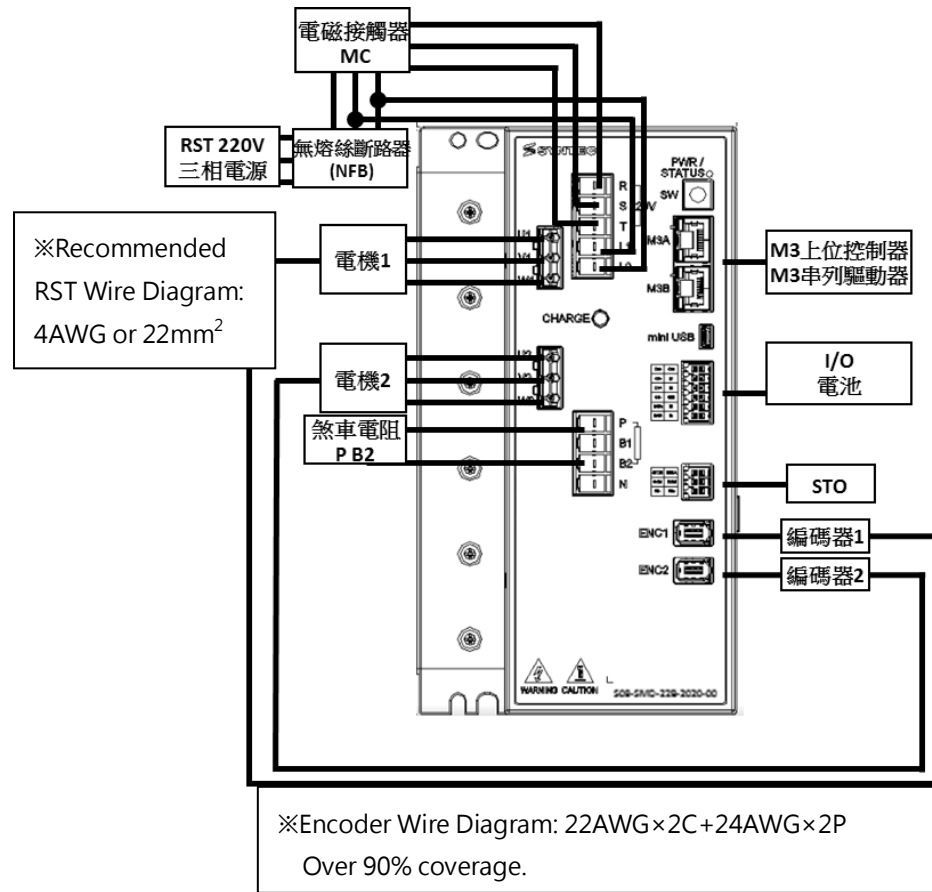

8. Interface Configurations

Please notice the value and the polarities of voltages.

● Mini USB Port Arrangement

Mini USB	PIN	SIGNAL
1	5V	
2	DM	
3	DP	
4	GND	
5	GND	

● STO Signal Port

STO	PIN	SIGNAL	PIN	SIGNAL
1	1	STO-A	2	STO-B
3	3	STO-COM	4	STO-COM
5	5	STO-FB+	6	STO-FB-

● Encoder Feedback Arrangement

編碼器回授	PIN	SIGNAL
1	5V	
2	GND	
3	BAT+	
4	BAT-	
5	D+	
6	D-	

● M3 Serial Communication Port Arrangement

M3	PIN	SIGNAL
1	1	TX+
2	2	TX-
3	3	RX+
4	4	NC
5	5	NC
6	6	RX-
7	7	NC
8	8	NC

● I/O Signal Port

I/O	1	7
1	O0+	CO1
2	O0-	10
3	O1+	11
4	O1-	C23
5	BAT+	12
6	BAT-	13

Notice : Contact capacity of output is DC30V, 200mA. Do not use in overload condition.

● Station Number Settings

站號設定	PIN	SIGNAL	PIN	SIGNAL
0	N/A	8	站號 8	
1	站號 1	9	站號 9	
2	站號 2	A	站號 10	
3	站號 3	B	站號 11	
4	站號 4	C	站號 12	
5	站號 5	D	站號 13	
6	站號 6	E	站號 14	
7	站號 7	F	站號 15	

9. Driver Specifications

Type	S08-SMD22B20-00	
Input Voltage	MAIN:AC 3PH 200~230V 50/60Hz CONT.:AC 1PH 200~230V 50/60Hz	
Input Current	MAIN:15A · CONT.:0.25A	
Output Voltage	Axis1~Axis2	AC 3PH 0~230V 0~400Hz
Rated Output Current	Axis1~Axis2	7.6A
Rated Power	Axis1~Axis2	1kW
Terminal Specifications	RST · PBN	Wire specifications : 30~10 AWG Operating temperature : -40°C~+115°C ; Rated torque : 0.69N · m
	U ₁ V ₁ W ₁ ~U ₂ V ₂ W ₂	Wire specifications : 28~12 AWG Operating temperature : -40°C~+115°C ; Rated torque : 0.51N · m
	I/O Signal Port	Wire specifications : 28~16 AWG ; Operating temperature : -40°C~+115°C
Environment Condition	TN System ⁽¹⁾	
	Allowable voltage deviation : -15% ~ +10% Allowable frequency deviation : -5% ~ +5%	
Environment Condition	Temperature	Operating Temperature : 0°C ~ 55°C (Not frozen. If the ambient temperature exceeds 45 °C, the air circulation system must be activated.) Storage/Transporting Temperature : -20~65°C (Not frozen)
	Humidity	Operating Humidity : Below 90%RH (Not Condensed), Storage/Transporting Humidity : Below 90%RH (Not Condensed)
	Surrounding Area	Indoor (Avoid direct sunlight), avoid corrosive gas, avoid flammable gas.
	Height	Operating/Storage Altitude (Max.) : 1,000 meters (With derating, usage is possible at the altitude between 1,000 m and 2,000 m.) Transporting Altitude (Max.) : 10,000 meters
Vibration	5.9 m/s ²	
Pollution Degree	2	
IP Level	IP20	
Frame Size	W × H × D mm 220 x 185 x 120	
Weight	3.95Kg	

(1) TN System: The neutral point of the power system is grounded directly to earth, and the exposed metal components are grounded by protective earthing conductors.

10. Wiring Notifications

- When using a solenoid valve or other inductive loads, please apply an arc extinguisher or an RC varistor to ensure the life of the contact points. Advantages of the arc extinguisher:
 - 1) Extend the life of electrical contacts.
 - 2) Reduce the sparks from the contact points.
 - 3) Restrain the impulse voltage.
 - 4) Prevent the inductive loads from interferences caused by back EMF.
- Do not connect other cables to extend the original length. It might cause signal errors or malfunction.
- Please crimp or weld the wire connections while doing the wirings.
- If the servo line in use is not a standard Syntec cable, please verify all the terminals are connected properly before power-on. Wrong wirings will lead to controller output command errors and malfunctioning.
- The +5V output capacity of the encoder is 500mA and is only for a single encoder. Do not connect it with other loads or it might cause error due to the lack of driving force.
- If the servo line in use is not a standard Syntec cable, please verify all the terminals are connected properly before power-on. Wrong wirings will lead to controller output command errors and malfunctioning.
- The wiring of the driver and the motor cannot be pulled too tightly.
- Do not stake on top.
- The driver is fragile. Please handle it with care.
- Do not allow conductive foreign matter such as screws or metal chips, or combustible foreign matter such as oil enter the driver.
- The six power lines, R, S, T and U, V, W, should not be close to other signal lines, and should be at least 30 cm apart.
- After cutting off the power, the capacitor of the driver still contains large amount of charge. Do not touch the 6 power lines, R, S, T and U, V, W, until the power indicator goes out.
- If the encoder line should be longer, please use twisted-pair and signal cable with isolated ground. Do not extend it over 20 meters. In case of extensions over 20 meters, please double the wire diameter of signal cables to reduce signal attenuation.
- To ensure the quality of communication, the USB extension cord in use should not exceed 5 meters, and do not use for charging purposes to avoid controller failure.
- Applicable motors: Please refer to the selection manual.
- Please comply with the wire gauge standards. The recommended wire diameter varies with the motor wattage. Please refer to the table below:

Type	Wattage	Wire Diameter
Axial	100W~850W	20AWG
	850W~7.5kW	16AWG
Spindle	Below 7.5kW(include)	12AWG
	Above 11kW(include)	10AWG

- Please connect the ground wire to class-3 (under 100Ω). Poor grounding might cause signal error, electric shock, or fire.
- The grounding of the motor must be connected to one of the grounding terminals of the frequency converter.

- In accordance with EN 61800-5-1 (Section 4.3.5.5.2), since the normal contact current of the frequency converter is higher than 3.5 mA AC or 10 mA DC, a fixed protective earthing connection must be used.

- 1) The cross-sectional area of the protective earthing wire should be copper wires of at least 10mm² or aluminum wires of at least 16mm².
- 2) Automatically cut off the power when the protective earthing conductor is interrupted.
- 3) Replace the original protective earthing conductor with a spare one that has the same cross-sectional area.

- Grounding Directions:

- 1) The length of grounding wires should comply with the electrical equipment regulations; the shorter the better.
- 2) The grounding wire of the driver should be grounded separately with high-current loads such as electric welders or high frequency motors.
- 3) Please refer to the pictures below when the controller is grounded with multiple electrical control devices. Do not make it a loop.

