

S08-SMD-33B Series Three-in-one Driver

Basic Installation Instructions v1.0

Dear users, please go through the instructions in detail before the installation. Also, please hand the manual to the actual operator of the machine and preserve it properly.

Drivers are precision electronic devices. For the safety of both operators and the machine, please ensure all installations, tests and adjustments are operated by professional personnel. For the description with “DANGER”, “WARNING” and “CAUTION” in the manual, please read them in detail. If there are any concerns, please contact our branches in your region. Our professionals are glad to be at your service. The following are the guidelines you should comply with before finishing reading the complete manual:

- The installing environment should be indoor and without water vapor, corrosive or flammable gas.
- Implement the wirings according to the wiring diagram.
- The grounding must be strictly implemented and follow the current National Electrical Code. (References: NFPA 70: National Electrical Code,2005 Ed.)
- Do not modify the wirings while the device is powered up.

1. Safety Precautions

Please pay extra attention to the instructions below while operating the product.	
	<ul style="list-style-type: none"> ■ Install the driver according to the instructions in the manual or it might cause damage to the equipment. ■ Do not operate the product in places exposed to water vapor, corrosive or flammable gases. It might cause damage to the device, electric shocks, fire or explosion. ■ Do not install the product at a temperature exceeding the specified range. It might cause device damage or malfunctioning. ■ The driver series are designed to control the motors. Do not touch the internal circuits or parts while the driver is powered up. ■ The internal circuit board of the driver contains CMOS ICs, which are vulnerable to static electricity. Do not touch the circuit board with your hands before taking any precautions. ■ The product has been certified by EN 61800-5-1/EN 61800-3. It is for use in industrial environments. ■ Do not apply the product to machines that might lead to casualties, device damage or system shut down.
	<ul style="list-style-type: none"> ■ Please cut off all the external device loads when powering up the driver for the first time in case the built-in testing program starts running the motor immediately after power input. It may be dangerous for the operators around. ■ The driver is a precision instrument. Please prevent non-maintenance staff or non-professional electronic control personnel from disassembling the device. ■ Please apply the correct ground loop to prevent signal errors. ■ Please separate the communication cable of the driver from all the other motor and power cables with individual wiring ducks to prevent the controller from malfunction caused by large noise interference.
	<ul style="list-style-type: none"> ■ The driver adopts microcomputer design. Please install the driver in a safe area and keep the area clean. Please keep iron shavings, wires, water, corrosive gas and liquid from the driver to avoid malfunction. ■ Please reserve at least 50mm in width for ventilation and heat dissipation. ■ The grounding of the driver and machine tool system is necessary for leakage protection and prevention of lightning strikes. Please ensure the driver and the machine tool system are grounded properly before installing. ■ The power system of the driver should meet the rated voltage. If the operating environment provides an unstable voltage source, please apply a voltage stabilizer so that the driver can function properly. ■ Please turn off the power before plugging/unplugging the cables or modifying the wirings to prevent electric shocks or damage to the driver. ■ Please make sure all the terminals are in the correct positions while wiring to prevent the driver from damage caused by wiring mistakes. ■ Do not touch the terminals within 10 minutes after cutting off the power in case that the residual voltage might cause electric shocks. ■ Unload the driver after the driver is powered off after 30 minutes.

2. Installation Notifications

- The leakage current of an all-in-one driver is usually over 3.5mA. In accordance with EN 61800 5-1, fixed installation is required.
- The direction of the installation must comply with the regulations, otherwise it will cause servo failure.
- When installing the driver, the air intake and vent holes should not be sealed, and the driver should not be tipped; otherwise it will cause malfunctions.
- Do not install the driver near flammable materials.
- Ensure every mounting hole is locked up when fixing the driver.
- Ensure the installation surface can support the weight of the driver.

3. Driver Interface Instructions

(Top View)

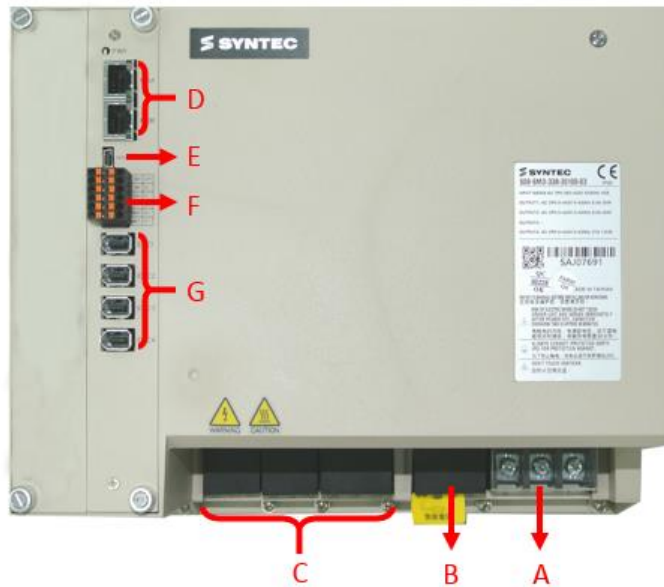

Driver Function

Label	Function	Description
A	External Power Supply	Connect to 380V three-phase electrical power (RST).
B	Regenerative Resistor	External regenerative resistor connects to P and B.
C	Machine Power Supply	Connect to motor and supply power (UVW). 3 sets in total, from the left to right are the 1 st , the 2 nd , and the 4 th axis.
D	MIII Serial Communication Port	Connect to the host controller (MIII Signal). Connect to the serial driver (MIII Signal).
E	Mini USB Port	Connect to personal computer.
F	I/O Signal Port	Connect to I/O equipment (the emergency stop, indicator lights, etc.)
G	Encoder Feedback	From top to bottom are the 1 st port to the 4 th connecting to motor encoders.

4. Controller Specifications (Unit: mm)

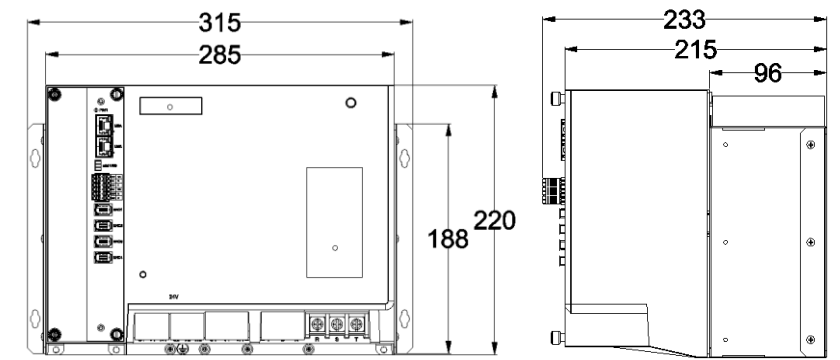

5. Installation Specifications (Unit: mm)

• Default Settings

(Top View)

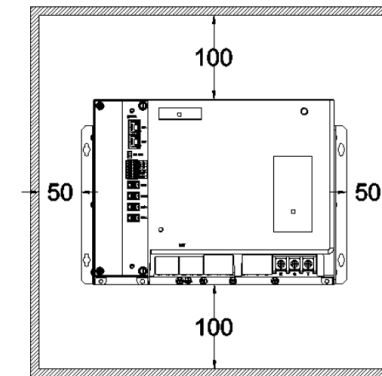

(Side View)

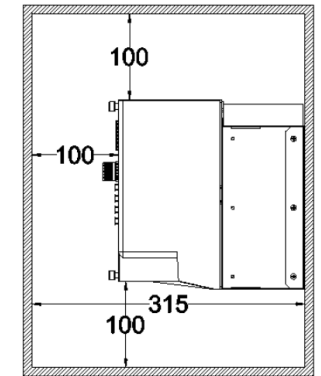

• Recommended Arrangement for Heat Dissipation

For heat dissipation, operators may remove the original L-bracket on the bottom and attach it to the middle.

The hole on the middle for installing opposite.

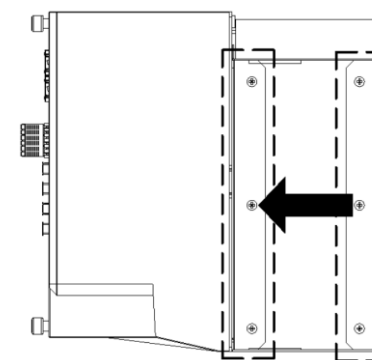

(Top View)

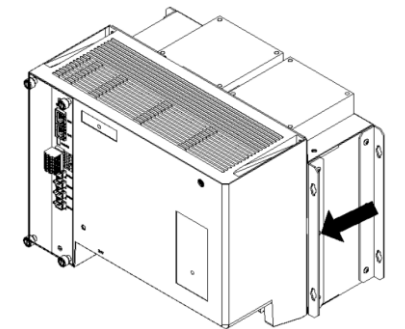
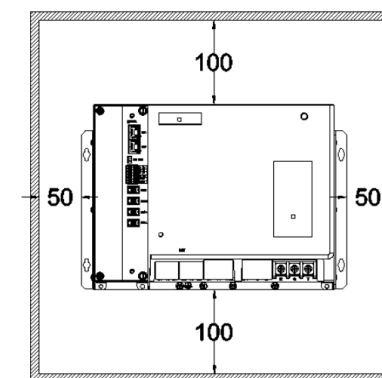

(Side View)

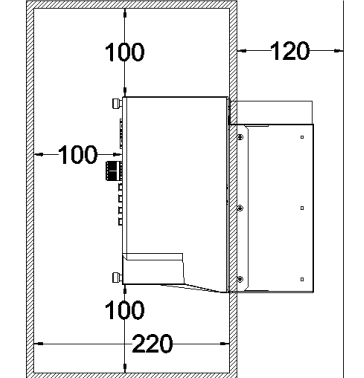

6. Mounting Hole Specification (Unit: mm)

Please install with M4 screws.

● Default Settings

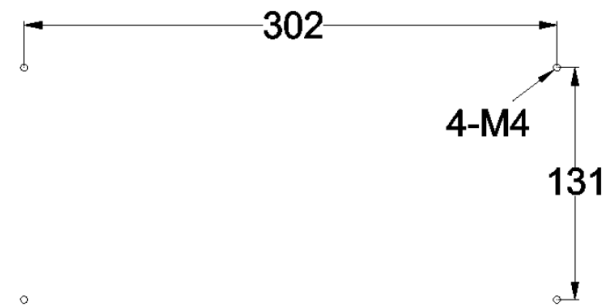

● Recommended Arrangement of Heat Dissipation

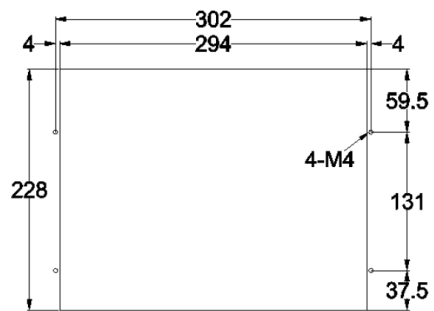

7. Basic Wiring Diagram

- Please Confirm whether the wiring of the U, V, W terminals output to the motor is correct, otherwise it may cause reversal or abnormality, and the encoder must be adjusted again.
- When wiring the host controller, either the general servo signal or the serial servo signal can be installed.

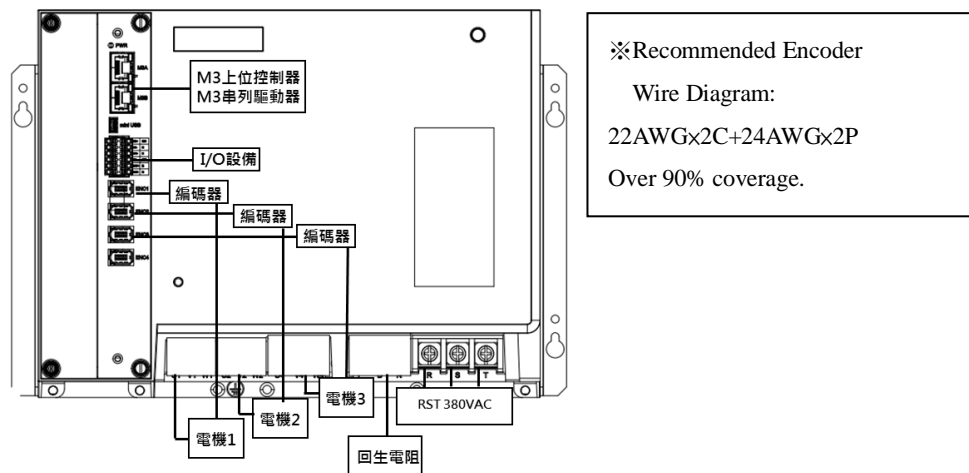

※Recommended Encoder

Wire Diagram:
22AWG×2C+24AWG×2P
Over 90% coverage.

8. Interface Configurations

Please notice the value and polarities of voltages.

- Serial Communication Port Arrangement
- Mini USB Port Arrangement
- Encoder Feedback Arrangement

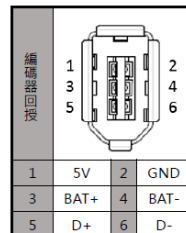
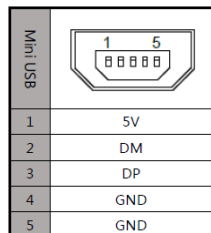
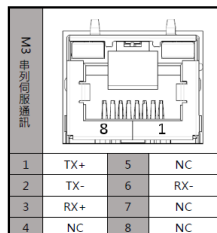

● I/O Signal Port Arrangement

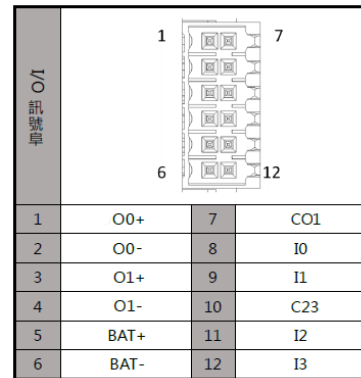

9. Driver Specifications

Type	S08-SMD33B2575-00	S08-SMD33B35100-00
Input Voltage	AC 3PH 380~460V 50/60Hz	
Input Current	46A	65A
Output Voltage	AC 3PH 0~440V 0~400Hz	
Rated output current	Axis1~Axis2: 5.4A Axis4: 21A	Axis1~Axis2: 8.4A Axis4: 27A
Rated Power	Axis1~Axis2: 1.5kW Axis4: 7.5kW	Axis1~Axis2: 2kW Axis4: 11kW
Terminal Specifications	RST、PBN、U ₁ V ₁ W ₁ Wire Specifications: 65A 14~6AWG/85A 4AWG(Sol)/100A 4~3 AWG(Str) Operating Temperature: -40°C~+130°C ; Rated Torque: 2.4N·m U ₁ V ₁ W ₁ ~U ₂ V ₂ W ₂ Wire Specifications: 30~10 AWG ; Operating Temperature: -40°C~+105°C ; Rated Torque: 0.69N·m I/O Signal Port ADDA Second Feedback Wire Specifications: 28~16 AWG; Operating Temperature: -40°C~+115°C	
Power Source Environment	TN System ⁽¹⁾ Allowable voltage deviation: -15% ~ +10% Allowable frequency deviation: -5% ~ +5%	
Environment Condition	Temperature: Operating: 0°C ~ 55°C (Not frozen. If the ambient temperature exceeds 45°C, the air circulation system must be activated.) Storage/Transporting: -20~65°C (Not frozen) Humidity: Operating: Below 90%RH (Not condensed) Storage/Transporting: Below 90%RH (Not condensed) Surrounding Area: In door (Avoid direct sunlight), avoid corrosive gas, avoid flammable gas Height: Operating/Storage Altitude (Max.): 1,000 meters (With derating, usage is possible between 1,000 m and 2,000 m.) Transporting Altitude (Max.): 10,000 meters Vibration: 5.9 m/s ²	
Pollution Degree	2	
IP Level	IP10	
Frame Size W × H × D mm	315 × 212 × 220	
Weight	7.5Kg	

NOTE :

- (1) TN System: The neutral point of the power system is grounded directly to earth, and the exposed metal components are grounded by protective earthing conductors.

10. Wiring Notifications

- When using a solenoid valve or other inductive loads, please apply an arc extinguisher, an RC varistor, or a flyback diode to ensure the life of the contact points. Advantages of the arc extinguisher:
 - 1) Extend the life of electrical contacts.
 - 2) Reduce the sparks from the contact points.
 - 3) Restrain the impulse voltage.
 - 4) Prevent the inductive loads from interferences caused by back EMF.

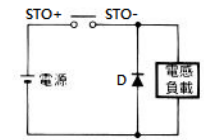

▲ Flyback diode circuit diagram

$$\text{機床變壓器容量選擇(KVA)} = \frac{[\text{n台變頻器功率加總(KW)} + \text{驅控一體所接電機總功率(KW)} + \text{控制電源盒(KW)} + \text{其他接電壓器後的負載功率}]}{0.7(\text{視在功因率})} \times 1.1$$

Suppose a client wants to drive four 1.2kW motors with 1kW*4 Servo Drive Embedded Controller, it means the gross power should supply at most 4.8kW. Then we reverse the formula and set the power factor at 0.7. If only Servo Drive Embedded Controllers are used, the capacity should be at least 4.8/0.7=6.85kVA. In addition, 10% of the backup capacity should be considered. Thus, 7.5kVA would be more suitable. Moreover, if an inverter is used, and the power is supplied by an isolation transformer, the capacity of the inverter should be considered.

- Do not connect a cable with other cables to extend the length. It might cause signal error or malfunction.
- Please crimp or weld the wire connections while doing the wirings.
- If the servo line in use is not a standard Syntec cable, please verify all the terminals connected properly before power-on. Wrong wirings will lead to controller output command errors and malfunctioning.
- The +5V output capacity of the encoder is 500mA and is only for a single encoder. Do not connect it with other loads or it might cause error due to the lack of driving force.
- Do not use counterfeit terminal strips. Those terminal strips cannot provide overall protection for the system. The quality is also not guaranteed and tend to cause electrical control problems of the machine tools.
- The wiring of the driver and the motor cannot be pulled too tightly.
- Do not stake on top.
- The six power lines, R, S, T and U, V, W, should not be close to other signal lines, and should be at least 30 cm apart.
- After cutting off the power, the capacitor of the driver still contains large amount of charge. Do not touch the 6 power lines, R, S, T and U, V, W, until the power indicator goes out.
- If the encoder line should be longer, please use twisted-pair and signal cable with isolated ground. Do not extend it over 20 meters. In case of extensions over 20 meters, please double the wire diameter of signal cables to reduce signal attenuation.
- To ensure the quality of communication, the USB extension cord in use should not exceed 5 meters, and do not use for charging purposes to avoid controller failure.
- The drive is fragile. Please handle it with care.
- Do not allow conductive foreign matter such as screws or metal chips, or combustible foreign matter such as oil enter the driver.

- Applicable motors: Please refer to the selection manual.
- Please comply with the wire gauge standards. The recommended wire diameter varies with the motor wattage. Please refer to the table below:

Type	Wattage	Wire Diameter
Axial	100W~850W	20AWG
	850W~7.5kW	16AWG
Spindle	Less than 7.5kW (Include)	12AWG
	More than 11kW(Include)	10AWG

- Please connect the ground wire to class-3 (under 100Ω). Poor grounding might cause signal error, electric shock, or fire.
- The grounding of the motor must be connected to one of the grounding terminals of the frequency converter.
- In accordance with EN 61800-5-1 (Section 4.3.5.5.2), since the normal contact current of the frequency converter is higher than 3.5 mA AC or 10 mA DC, a fixed protective earthing connection must be used.
 - 1) The cross-sectional area of the protective earthing wire should be copper wires of at least 10mm² or aluminum wires of at least 16mm².
 - 2) Automatically cut off the power when the protective earthing conductor is interrupted.
 - 3) Replace the original protective earthing conductor with a spare one that has the same cross-sectional area.
- Grounding Directions:
 - 1) The length of grounding wires should comply with the electrical equipment regulations; the shorter the better.
 - 2) The grounding wire of the driver should be grounded separately with high-current loads such as electric welders or high frequency motors.
 - 3) Please refer to the pictures below when the controller is grounded with multiple electrical control devices. Do not make it a loop.

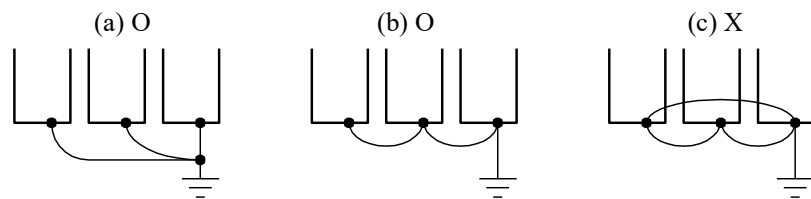

11. Waste Disposal



- 1) When a product comes to the end of its life, please recycle it in accordance with the local regulations and treat it as industrial waste.
- 2) To recycle a product, we usually sort the components into steel shavings, electrical parts, etc.; then we sell them to licensed industrial waste management companies.
- 3) The batteries of the products should be recycled in accordance with the local law.