

Serial FC Controller

Basic Installation Instructions V1.3

Dear users, please go through the instructions in detail before the installation. Also, please hand the manual to the actual operator of the machine and preserve it properly.

CNC controllers are precision electronic devices. For the safety of both operators and the machine, please ensure all installations, tests, and adjustments are operated by professional personnel. For the description with “DANGER”, “WARNING” and “CAUTION” in the manual, please read them in detail. If there are any concerns, please contact our branches in your region. Our professionals are glad to be at your service.

The following are the guidelines you should comply with before finishing reading the complete manual:

- The installing environment should be indoor and without water vapor, corrosive or flammable gas.
- Implement the wirings according to the wiring diagram.
- Implement the grounding strictly and follow the current National Electrical Code.
(References: NFPA 70: National Electrical Code, 2005 Ed.)
- Do not modify the wirings while the device is powered up.

Applicable Types

Type	Product Name
1 F31-FC-B	FC Serial Axis Controller
2 F31-FC-B-5	FC-B-5 Serial Axis Controller
3 F31-FC-B-80RA	FC- Serial Articulated_ Robot
4 F31-FC-B-80RD	FC- Serial DELTA_ Robot
5 F31-FC-B-80RG	FC- Serial Pick and Place Gantry_ Robot
6 F31-FC-B-80RS	FC- Serial SCARA_ Robot
7 F31-FC-B-60CB	60CB Economacal Woodworking PLC Controller
8 F31-FC-B-60DB	FC- Serial Axis Controller_ Drilling Machine
9 F31-FC-B-60WA	FC Serial Axis Controller_ Woodworking Machine
10 F31-FC-B-60PA	FC Serial Axis Controller_ Woodworking Machine

1. Safety Precautions

Please pay extra attention to the instructions below while operating the product.



- Please install the controller according to the manual or it might cause damage to the equipment.
- Do not operate the product in places exposed to water vapor, corrosive, or flammable gases. It might cause damage to the device, electric shocks, fire, or explosion.
- Do not install the product at a temperature exceeding the specified range. It might cause device damage or malfunctioning.
- The controller series is designed to control the motor of the machine tool and manage the IO control. Do not touch the internal circuits or components while the controller is powered up. It might cause electric shock or device damage.



- The internal circuit board of the driver contains CMOS ICs, which are vulnerable to static electricity. Do not touch the circuit board with your hands before taking any precautions.
- The product has been tested and found to comply with the limits for a KC Class A Commercial equipment) digital device, which was for use in commercial and industrial environments instead of households.
- Do not apply the product to machines that might lead to casualties, device damage or system shut down.



- Please cut off all the external loads when powering up the controller for the first time. The built-in testing PLC program may start the motor immediately after power-up, which might be dangerous for the staff around.
- The controller is a precision instrument. Please prevent non-maintenance staff or non-professional electronic control personnel from disassembling the device.
- Please apply the correct ground loop to prevent errors from the controller.
- Please separate the communication cable of the driver from all the other motor and power cables with individual wiring ducks to prevent the controller from malfunction caused by loud noise interference.



- The CNC controller adopts a microcomputer design. Please install the controller in a safe area and keep it clean. Please keep iron shavings, wires, water, corrosive gas, and liquid from the driver to avoid malfunction.
- Storage temperature range: -20°C~60°C
Storage relative humidity range: 0% to 90% and without condensation.
- Operating temperature range: -10°C~55°C
Please reserve at least 50mm in width for ventilation and heat dissipation.
- The grounding of the controller and machine tool system is necessary for leakage protection and prevention of lightning strikes. Please ensure the driver and the machine tool system are grounded properly before installing.
- The rated voltage of the controller power system should not exceed DC18~32V. If the operating environment provides an unstable voltage source, please apply a voltage stabilizer so that the controller can function properly.
- Please turn off the power before plugging/unplugging the cables or modifying the wirings to prevent electric shocks or damage to the driver.
- Please ensure all the terminals are in the correct positions while wiring to prevent the driver from damage caused by wiring mistakes.
- Do not touch the terminals within 10 minutes after cutting off the power in case the residual voltage might cause electric shocks.
- Do not touch the panel with sharp objects or it might cause malfunction due to depression.
- To ensure communication quality, the length of USB extension cords in use shall not exceed five meters. Besides, do not charge or supply power via the USB port; otherwise, it may cause controller malfunction.

2. Wiring Notifications

- Each FC controller can connect up to 10 sub-modules.
When more sub-modules are needed, please purchase the FC-PWR module and connect according to the Basic Wiring Diagram.
- MPG terminal's +5V output capacity is 200mA and is only for a single external MPG. Do not connect it to other loads or it might cause errors due to the lack of driving force.
- The attached DC24V power adapter is only for the FC main module.
Please use additional supplies to provide DC24V power of sub-modules and I/Os since sharing the same supply with main modules might cause interference.
- The external DC24V power supply used in wiring should be certificated and protective to avoid the malfunction due to wiring mistakes.
(Recommendation standard : fulfill requirements of both EN60950 & UL1950)
- Please crimp or weld the wire connections while doing the wirings.
- When using a solenoid valve or other inductive loads, please apply an arc extinguisher or an RC varistor to ensure the life of the contact points. Advantages of the arc extinguisher:
 - 1) Extend the life of electrical contacts.
 - 2) Reduce the sparks from the contact points.
 - 3) Restrain the impulse voltage.
 - 4) Prevent the inductive loads from interferences caused by back EMF.
- In case of the use of Ethernet, to prevent internet congestion and noise, the CAT5e or CAT6 cable is recommended.
- To avoid noise interference, it is recommended to use Syntec standard SRI cables to connect to Syntec controllers. As for the cables connecting to other FC modules, shielded twisted pairs are recommended.
- Please connect the ground wire to class-3 (under 100Ω). Poor grounding might cause signal errors, electric shock, or fire.
- Do not connect other cables to extend the original length. It might cause signal errors or malfunction.
- If the servo line in use is not a standard Syntec cable, please verify all the terminals are connected properly before power-on. Incorrect wirings will lead to controller output command errors and malfunctioning.
- Grounding Directions:
 - 1) **The guide rail of FC Controller sets must be grounded.**
 - 2) The length of grounding wires should comply with the electrical equipment regulations; the shorter the better.
 - 3) Ground the grounding wire of the driver separately with high-current loads such as electric welders or high-frequency motors.
 - 4) Please refer to the pictures below when the controller is grounded with multiple electrical control devices. Do not make it a loop.

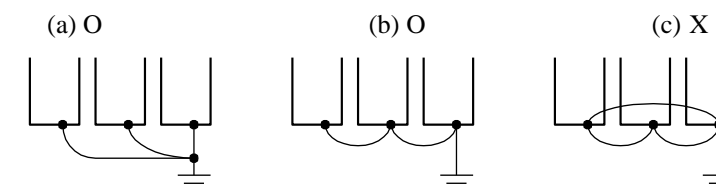

3. Waste Disposal Advice



- 1) When a product comes to the end of its life, please recycle it by the local regulations and treat it as industrial waste.
- 2) To recycle a product, we usually sort the components into steel shavings, electrical parts, etc.; then we sell them to licensed industrial waste management companies.
- 3) Recycle the batteries of the products by following the local law.

4. FC Controller Interface Specifications

(Front View)

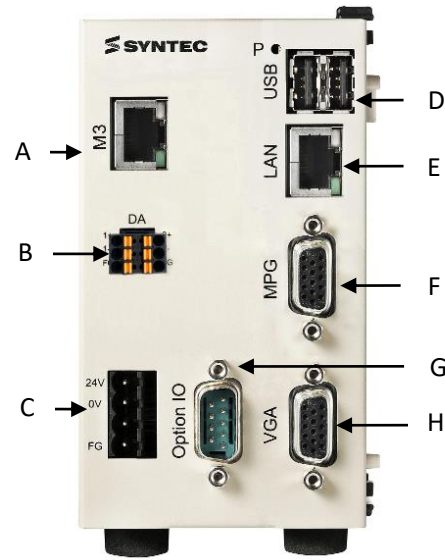

A	M3	M3 Serial Communication Interface
B	DA Output	DA Output Interface
C	24V Power Input	24V Power Input (Current need: 1A)
D	USB Port	Connect to the USB to store processing files.
E	LAN Port	Connect to the Internet.
F	MPG Port	Connect to the MPG.
G	Option IO Port	Connect to FC I/O modules; provide I/O functions.
H	VGA Port	Connect to external the VGA monitor.

(Side View)

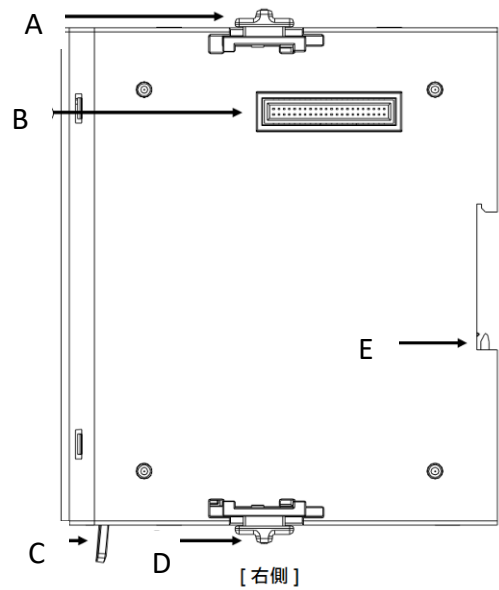

A	Upper Fastener	Connect to the upper fasteners of other FC sub-modules.
B	Internal Communication Port	Connect to other FC sub-modules.
C	Slide Tenon Batch	Control the batch of the slide tenon.
D	Lower Fastener	Connect to the lower fasteners of other FC sub-modules.
E	Slide Tenon	Fix the tenon on the slide.

5. External Dimension (Unit: mm)

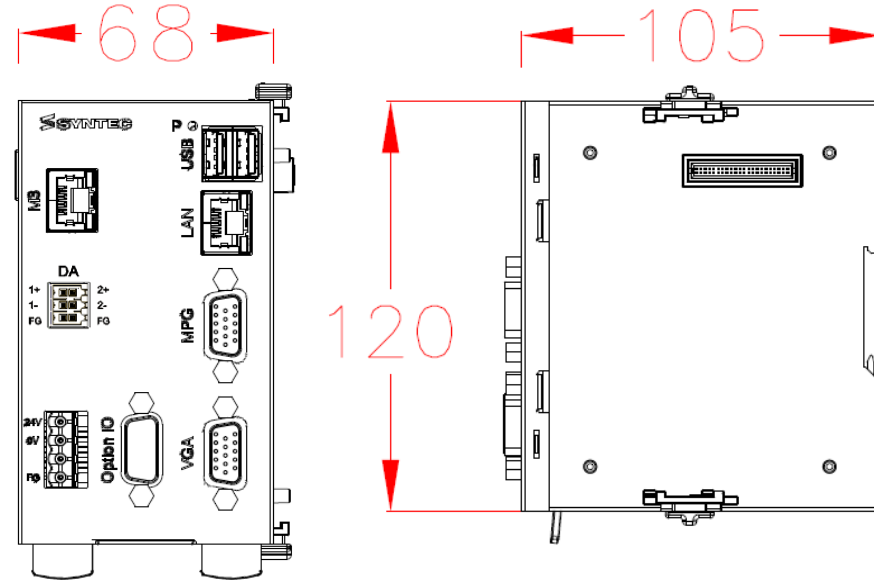

6. Basic Wiring Diagram

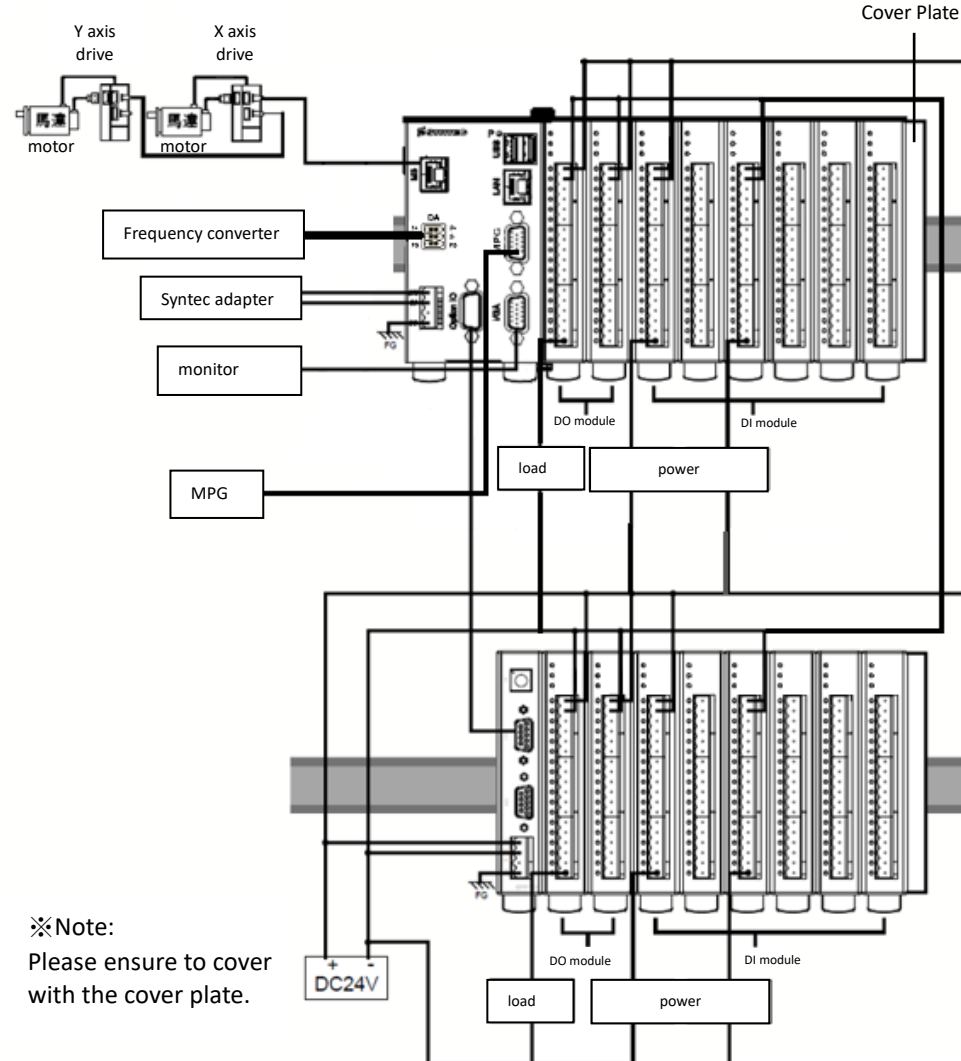

※Note:
Please ensure to cover with the cover plate.

7. Interface Configurations

● M3 Serial Communication Interface Connector Arrangement

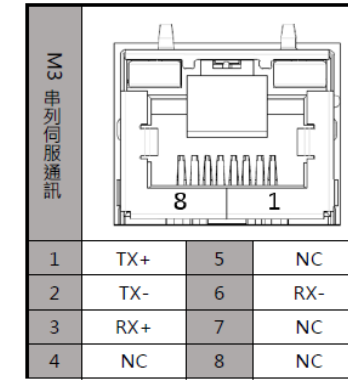

● MPG Connector Arrangement

MPG	PIN	SIGNAL	PIN	SIGNAL	PIN	SIGNAL
1	1	A+	6	--	11	MPG_IN4
2	2	A-	7	MPG_IN0	12	MPG_IN5
3	3	B+	8	MPG_IN1	13	MPG_IN6
4	4	B-	9	MPG_IN2	14	GND
5	5	--	10	MPG_IN3	15	5V

Note:

MPG_IN0~MPG_IN6 correspond to I56~I62 of PLC

● Option IO Connector Arrangement

Option I/O	PIN	SIGNAL	PIN	SIGNAL
1	1	SR15_D+	6	RS485_D-
2	2	SR15_D-	7	RS485_D+
3	3	SR16_D+	8	--
4	4	SR16_D-	9	5V
5	5	GND	10	--

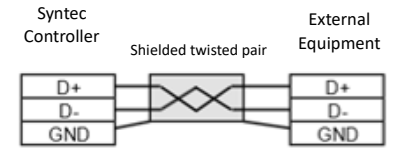

※Note: Please apply shielded twisted pair when using the RS485 interface. Besides the D+ and D- signal cables, please ensure the air gap is connected to GND on both sides to prevent the RS485 interface from burning down.

● Power Connector Arrangement

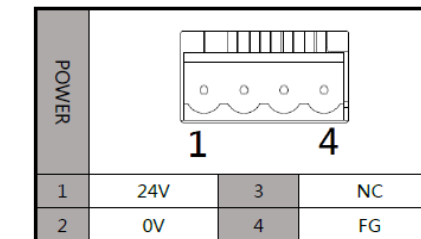

● DA Connector Arrangement

