

ST3025-SK6-M Panel

High speed, High Accuracy. The most trustworthy electrical control partner in the machine tool industry.

Basic Installation Instructions v1.1

Dear users, please go through the instructions in detail before the installation. Also, please hand the manual to the actual operator of the machine and preserve it properly.

The second panels are precision electronic devices. For the safety of both operators and the machine, all installations, tests, and adjustments shall be operated by professional personnel. Heed all the descriptions with “DANGER,” “WARNINGS,” and “CAUTION” in the manual. For help and service, please contact the branches in each region. Our professionals are glad to be at your service.

1. Safety Precautions

Please pay extra attention to the instructions below while operating the product.

	<ul style="list-style-type: none"> The panel series is to control the machine tool and the IO control. Do not touch the internal circuits or components while the controller is powered up. The internal circuit board of the driver contains CMOS ICs, which are vulnerable to static electricity. Do not touch the circuit board with hands before taking any precautions.
	<ul style="list-style-type: none"> The panel is a precision device. Non-maintenance staff or non-professional electronic control personnel shall not disassemble the panel.
	<ul style="list-style-type: none"> Please install the panel in a safe area and keep it clean. Please keep iron shavings, wires, water, corrosive gas, and liquid from the IPC to avoid malfunction. Storage temperature range: -40°C~70°C Storage humidity range: 0% to 90% and without condensation. Operating temperature range: -10°C~55°C. Please reserve at least 50mm in width for ventilation and heat dissipation. The grounding of the panel and the machine tool is necessary for leakage protection and prevention of lightning strikes. Please ensure the system and the machine tool are grounded properly before installing. The rated voltage of the panel power system shall not exceed 5V±20%. If the operation area provides an unstable voltage source, please apply a voltage stabilizer so that the panel can function normally. Please turn off the power before plugging/unplugging the cables. Otherwise, it may cause damage to the panel or electric shock. Please ensure all the terminals are in correct positions while wiring to prevent the panel from damage caused by wiring mistakes.

2. Interface Specifications

(Front View)



A	Keys	F1~F8 Functions	E	Button	Emergency Stop
B	Keys	Script Input	F	Knobs	Band Selections
C	Keys	Function selection of the machine	G	Buttons	Power Switch
D	Buttons	Program Switch			

(Rear View)

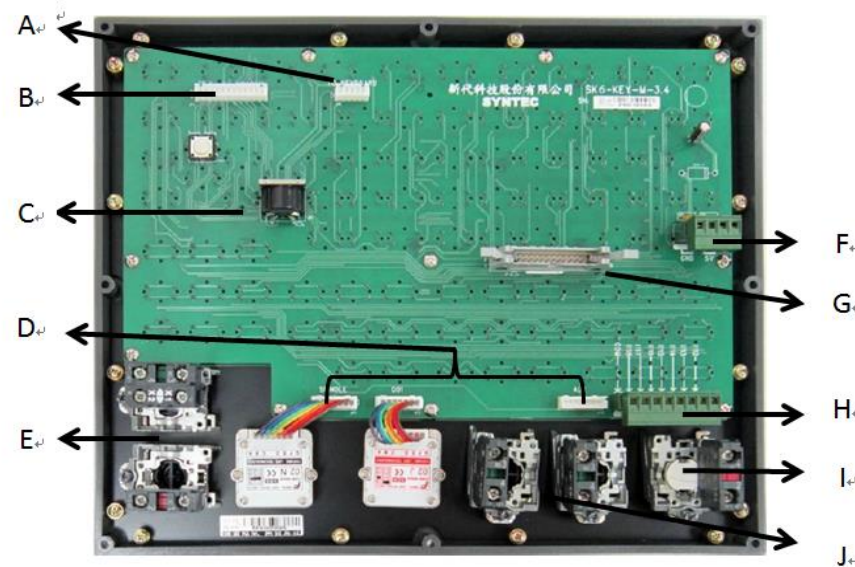

A	DIN Connector	Keyboards data output
B	Fenubars cables connectors	Connect to fenubars of the monitor
C	PS2 Port	Keyboard data output
D	7P Connector	Band data output switches
E	Illuminated Push Button Switch	Power Switch
F	Working power of the panel	5V Working Power Input
G	I/O Port	I/O data input/output port
H	Extension Point I Port	Extension Point I; for customers' use
I	Emergency Stop Connector	For emergency stop circuit
J	Illuminated Push Button Switch	Execute/Stop the program

3. External Dimensions (Unit: mm)

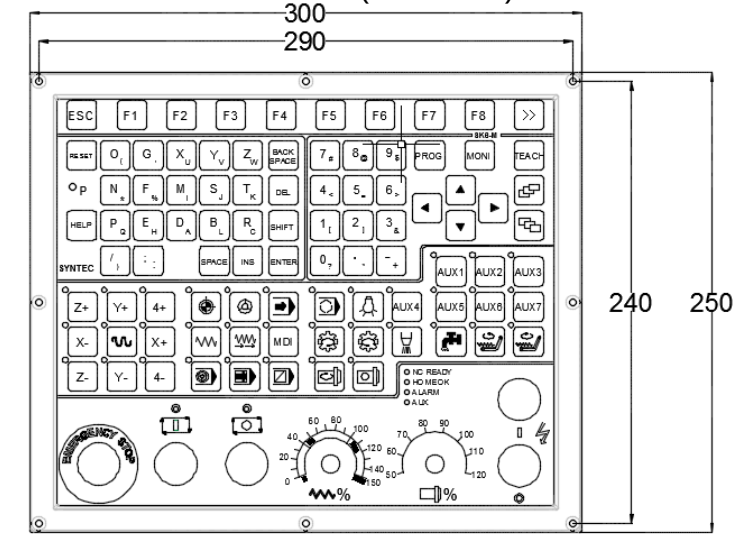

4. Installation Specifications (Unit : mm)

(Front View)

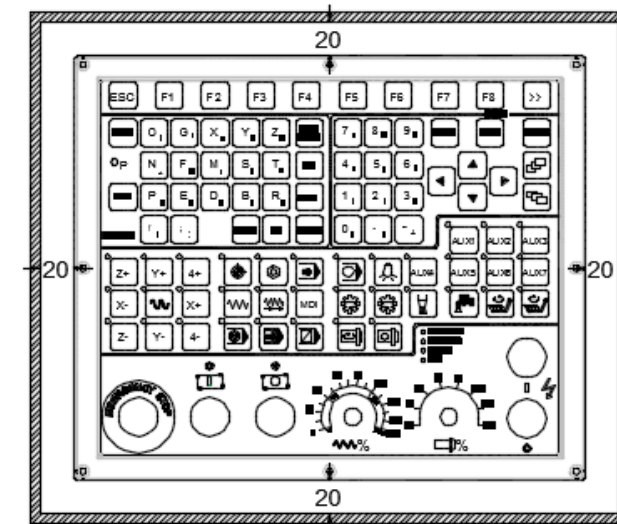

5. Mounting Hole Specifications (Unit : mm)

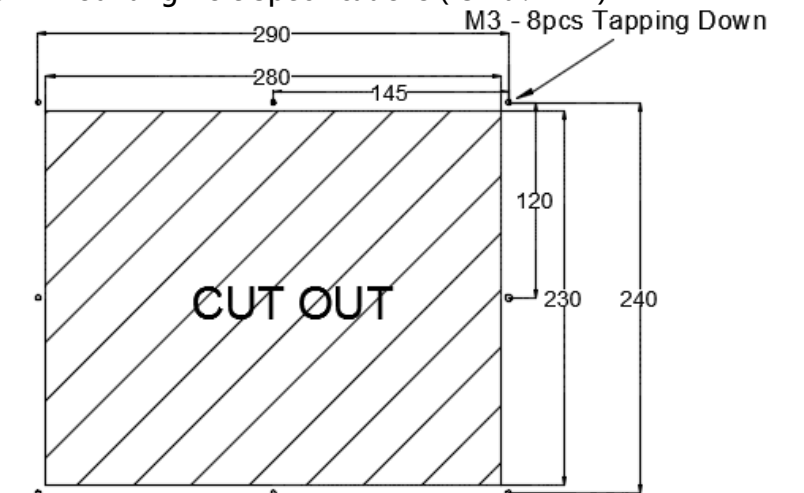

6. Parameter Setting of the Controller

No.	Description	Input Range	Input Value
3217	Select the type of the keyboard of the controller panel.	[0,3217]	1

7. I/O Configurations

IO Corresponding Graph of Product Keys: The corresponding point of I & O

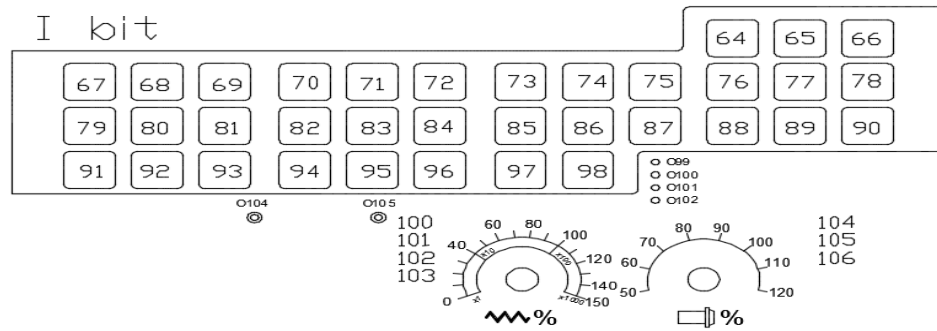

8. Interface Configurations

Please notice the value and polarities of voltages.

● HK Connector Arrangement



HK	PIN	SIGNAL	PIN	SIGNAL
26	26	—	25	XDI55
25	24	XDI54	23	XDI53
	22	XDI52	21	XDI51
	20	XDI50	19	XDI49
	18	XDI48	17	5V
	16	GND	15	XDO62
	14	XDO61	13	XDO60
	12	XDO59	11	XDO58
	10	XDO57	9	XDO56
	8	XDO55	7	XDO54
	6	XDO53	5	XDO52
	4	XDO51	3	XDO50
	2	XDO49	1	XDO48

9. HK Keyboard Specifications

Icon	Function	Operating Procedures
	Automatic processing mode: Execute the NC program with this method.	<ol style="list-style-type: none"> Turn the mode button to “AUTO.” The automatic processing mode works after the original point returns. Set the working coordinate (G54..G59). If no G54..G59 is set, the CNC value is G54 in the NC program. Set the tool radius compensation and tool length compensation at the “Tool Settings.” Press “Start” to execute the NC program. Press the "Emergency Stop Switch" to pause the NC program if necessary.
	MDI processing mode: The mode can execute the Single Block program without executing the NC program.	<ol style="list-style-type: none"> Turn the mode button to “MDI.” The MDI mode works after returning to “HOME.” Select F4 “Execute processing screen” at the home screen. Press F3 “MDI input,” and a dialog will show on the screen. After keying the data in the dialog, press

		<p>“Enter.”</p> <p>(6) Press “Start” to execute an MDI single block program.</p>
	<p>Find “Home” with the HOME mode:</p> <p>When the CNC is on, to find “Home” with the HOME mode is necessary.</p>	<ol style="list-style-type: none"> Turn the mode button to “HOME.” Control “X+, X-, Y+, Y-, Z+, Z-” according to the movement direction of the motor. The CNC starts to return to “HOME.”
	<p>JOG mode:</p> <p>Control the movement of machines with this method.</p>	<ol style="list-style-type: none"> Turn the mode button to “JOG.” Control “X+, X-, Y+, Y-, Z+, Z-” according to the movement direction of the motor. With the band, operators can adjust the cutting amount in the JOG mode. Press the “machine movement key” and the “fast displacement key” at the same time, and the CNC motor will move at the speed of “G00.” Use the feed rate with G00% to move the machine.
	<p>INC JOG mode:</p> <p>With INC JOG mode, press “JOG” to move the machine.</p>	<ol style="list-style-type: none"> Turn the mode button to “INC JOG” Press machine movement keys, “X+, X-, Y+, Y-, Z+, Z-” to move with a certain distance. Able to adjust a fixed range with the “rotary switch” G00. <p>The moving distance: *1 : 1um , *10 : 10um , *100 : 100um</p>
	<p>MPG JOG mode:</p> <p>When the CNC is power on, finding “HOME” with “HOME” mode is required.</p>	<ol style="list-style-type: none"> Turn the mode button to “INC JOG.” Select the axis to be moved from the mode knob. Select the distance to be increased. Press machine movement keys, “X+, X-, Y+, Y-, Z+, Z-” to move with a certain distance. <p>The moving distance: *1 : 1um , *10 : 10um , *100:100um , *1000 : 1000um</p>
	<p>MPG analog mode:</p> <p>Check the NC program with this method.</p>	<ol style="list-style-type: none"> Turn the mode button to “AUTO.” Press the “MPGSIM” and the button light will be illuminated. Press “START” to execute the NC program. The CNC will change the status of the machine from “READY” to “Processing.” Rotate the “rotating MPG” if the machine is not moving. The faster the MPG (rotating handwheel) rotates, the faster the machine moves. The CNC stops when the MPG stops. Whether the program can process can be known from this function.

	<p>Optional Stop:</p> <p>Set the M01 of the NC program to stop or not with this method.</p>	<ol style="list-style-type: none"> Turn the mode button to “AUTO.” Press the “O.STOP” and the button light will be illuminated. Press “START” to execute the NC program. When “M01” is in the CNC execution program, the CNC will stop. The status of the CNC will change from “Processing” to “STOP.” This mode is for tool change and workpiece inspection.
	<p>Optional Single Block Jump:</p> <p>With this function, define the machine to run or to jump when meets “/.”</p>	<ol style="list-style-type: none"> Turn the mode button to “AUTO.” Press the “B.D.T” and the button light will be illuminated. Press the “START” button to execute the NC program. When the CNC meets “/,” it will jump the block automatically. If did not press the button, the CNC will run this block.
	<p>Single Block Executing:</p> <p>Test the NC program with this method.</p>	<ol style="list-style-type: none"> Turn the mode button to “AUTO.” Press the “S.B.K” and the button light will be illuminated. Press the “START” button to execute the NC program. The CNC will execute the NC program for only a block and stop. The CNC will change the status of the machine from “PROCESSING” to “STOP.” Press “START” again, and the CNC will execute the next block. This function is for checking the program block by block.
	<p>Axial arrow keys & forward/reverse keys of rotary axis & Rapid shift key: Control the axial movement. If pressed the rapid shift key together, it can move rapidly.</p>	
	<p>CW/CCW (Chip):</p> <p>Rotate the chip conveyor clockwise/counterclockwise or turn it on/off.</p>	 <p>MG CW/CCW: Rotate the tool magazine clockwise/counterclockwise.</p>
	<p>Air blow & fluid switch:</p> <p>Turn on/off the air blow and the fluid switch.</p>	 <p>Spindle CW: Rotate the spindle clockwise.</p> <p>Spindle Stop: Stop the spindle.</p>

	Light: Turn on/off the working light.		AUX1 (User-defined Button): Coordinate with the Ladder script. (AUX1~AUX7)
---	---	---	---

10. Wiring Notifications

- When using a solenoid valve or other inductive loads, please apply an arc extinguisher or an RC varistor to ensure the life of the contact points.
Advantages of the arc extinguisher:
 - 1) Extend the life of electrical contacts.
 - 2) Reduce the sparks from the contact points.
 - 3) Restrain the impulse voltage.
 - 4) Prevent inductive loads from interferences caused by back-EMF.
- Please crimp or weld the wire connections while wiring.
- The external 5V power supply used in wiring shall be certificated and protective to avoid the malfunction caused by wiring mistakes.
(Recommendation standard: fulfill requirements of EN60950 and UL1950)

- **Only dry contact switches can be used for the extension I point.**

Circuit Example:

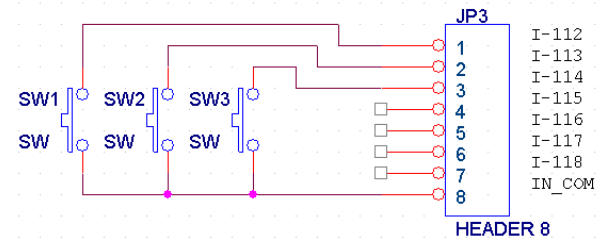

- **Extension O point can only drive LEDs without current limiting resistors.**

Circuit Example:

