

TAIWAN

Taiwan (Hsinchu)

SYNTEC Technology Co., Ltd
ADD : No.25, Yanfa 2nd Rd., East Dist.,
Hsinchu City 300, Taiwan (R.O.C.)
TEL : +886-3-6663553
FAX : +886-3-6663505
EMAIL : sales@syntecclub.com.tw

Taichung

SUN-CNC Co., Ltd
ADD : No. 22, Lane 428, Section 1, Fengyuan
Boulevard, Fengyuan District
TEL : +886-4-25337731
TAX : +886-4-25349224

TANLU-CNC Co., Ltd

ADD : No. 42, Jingming Road, Xitun District,
Taichung City, Taiwan (R.O.C.)
TEL : +886-4-23102626
TAX : +886-4-23102636

Tainan

ADD : No. 218, Denan Road, Rende District,
Tainan City, Taiwan (R.O.C.)
TEL : +886-6-2796707
TAX : +886-6-2796705

AROUND THE WORLD

Malaysia

ADD : 43, Ground Floor, Jalan Tpp1/1, Taman
Perindustrian Puchong, 47100, Selangor Darul Ehsan.
TEL : +603-61577632
EMAIL : ots.siah@syntecclub.com.tw;
yenearn.teoh@syntecclub.com.tw

Thailand

ADD : 78/38 Kheha Romklao Rd., Khlong Song Ton Nun,
Lat Krabang, Bangkok, 10520
TEL : +662-006-5738
EMAIL : thanawat@syntecclub.com.tw

Vietnam

ADD : 3F, No. 36, A4 Street, Ward 12, Tan Binh District,
Ho Chi Minh City, VietNam
TEL : +84938332829
FAX : +842822535556
EMAIL : andyngo@vnsyntec.com.vn

Turkey

ADD : Kücükbakkalkoy Mah. Vedat Günyol Cd. Defne Sok.
No:1 D:1502 Flora Residence,34750 Atasehir/Istanbul, Türkiye
TEL : +90-216-2662475
EMAIL : daisy.cheng@syntecclub.com.tw

USA (South California)

ADD : 766 Pinefalls Ave, Walnut, CA 91789
TEL : +1909-551-0187
EMAIL : info@syntecamerica.com

Indonesia

PT. OTOMASI BERSAMA INDONESIA
ADD : Ruko Arcadia Mataram Blok B, No 15, Kelurahan
Cibatu, Kecamatan Cikarang selatan, 17530, Indonesia
TEL : +6221 2210 4832
EMAIL : yulius@otomasi.co

CHINA

Jiangsu

SYNTEC Equipment CO.,Ltd.
ADD : Building B, Kejiyuan, Xindai, No. 9, Chunhui Road,
Suzhou Industrial Park
TEL : 0512-69008860
FAX : 0512-65246029

Jiangsu-Suzhou

Suzhou Huaxin Numerical Control Technology
Development Co.,Ltd.
ADD : Building A, Kejiyuan, Xindai, No. 9, Chunhui Road,
Suzhou City Industrial Park
TEL : 0512-69008860
FAX : 0512-69560818

Nantong

Suzhou New Generation CNC Equipment Co., Ltd.
Nantong Branch (NTST)
ADD : Building A, Kejiyuan, Xindai, No. 9, Chunhui Road,
Suzhou City Industrial Park
TEL : 0513-89077025

Jiangsu-Nanjing

The Suzhou new generation of CNC Equipment
Co., Ltd. Chongqing Branch
ADD : Room 104, Unit 2, Building 6, Jiulonghu Villa, No. 188,
Qingshuiing West Road, Jiangning District, Nanjing City
TEL : 025-52717710
FAX : 025-52717702

Anhui Hefei

Suzhou new generation numerical control
equipment Co., Ltd. Hefei branch
ADD : Hefei Binhu Baohe District Century City
Fu Hui Yuan T4-2202map
TEL : 0551-63814183

Shaanxi

Shaanxi Xi'an
The Suzhou new generation of CNC Equipment
Co., Ltd. Xi'an Branch
ADD : Room 11328, Unit 1, Building 4, Duhui, 1, Yicuiyuan,
No. 10, Tangyan South Road, Gaoxin District, Xian City
TEL : 029-88287423
FAX : 029-88287423

Wuxi

Suzhou Huaxin CNC Technology Development
Co., Ltd. Wuxi Office
ADD : B906, Yuye Network Building, No. 68, Tansuo Road,
Huishan District, Wuxi
TEL : 15295664580

Guangdong

Suzhou SYNTEC Equipment Co.,Ltd. Guangdong
Branch
ADD : 2F, Building 6, Dongguan-Taiwan Biotechnology
Incubation Center, No.1, Taiwan High-Tech Park, Songshan
Lake
TEL : 0769-22249073
FAX : 0769-22210012

Guangdong Dongguan

Suzhou SYNTEC Equipment Co.,Ltd. Dongguan
Branch Co., Ltd. Chongqing Branch
ADD : Zone B, 3F, Building 1, No.522,
Chain-An East Rd., Changan Townmap
TEL : 0769-81660318
FAX : 0769-81660328

Guangdong Guangzhou

Suzhou SYNTEC Equipment Co.,Ltd. Guangzhou
Branch
ADD : 2T1404, Zhiqi, No. 8, Luojia Village Section, Fuji Road,
Dalong Street, Panyu District, Guangzhou City
TEL : 020-34583040
FAX : 020-34583220

Chongqing

The Suzhou new generation of CNC Equipment
Co., Ltd. Chongqing Branch
ADD : Floor 5, Huihong Building, No. 8, Qianyi Road, Banshi
Village, Changping Town, Dongwan City
TEL : 0769-82826802
FAX : 0769-82826820

Shenzhen

Shenzhen branch
ADD : 5F, Building C, Sunshine Technology Park, Gin-Long
2nd Rd., Baolong Industrial Zone, Shenzhen Longgang District
TEL : 0755-84320380
FAX : 0755-84559490

Jiangmen

Suzhou New Generation CNC Equipment Co., Ltd.
Jiangmen Branch (JMST)
ADD : Room 02, Floor 7, Huoju Building, Gaoxin District, No.
288, Jinou Road, Jianghai District, Jiangmen City, Guangdong
Province
FAX : 0750-3771824

Changzhou

Syntec Technology (Suzhou) Co., Ltd. Nanjing
Branch Changzhou Office
ADD : Room 2217, Yatai Fortune Center, No. 1, Huayuan
Street, Hutang Town, Wujin District, Changzhou City
TEL : 18168828572

Xiamen

Suzhou SYNTEC Equipment Co.,Ltd. Xiamen
Branch
ADD : No. 100.8 Chuang Chang Fang 3F East Jih Fu Road,
Tong An District, Xiamen City, Fujian Province, China
TEL : +86-592-7191901
FAX : +86-592-7220536

Zhejiang

Zhejiang Hangzhou
Suzhou SYNTEC Equipment Co.,Ltd. Hangzhou
Branch
ADD : Room1202 Unit2 Building1, Edifice DiKai, Jincheng
Road, Beigan Street, Xiaoshan District , Hangzhou City, Zhejiang
Province, China
TEL : 0571-82751187
FAX : 0571-82751186

Zhejiang Ningbo

Suzhou SYNTEC Equipment Co.,Ltd. Ningbo
Branch
ADD : Room 12-07, No.262,416 Alley, Zhaohui Road,
Jiangdong District, Ningbo City.
TEL : 0574-87750305
FAX : 0574-87750306

Zhejiang Wenling

The Suzhou new generation of CNC Equipment
Co., Ltd. Wenling Branch
ADD : Room 1206, Department A, Zhenxing Plaza, Taiping
Subdistrict, Wenling Citymap
TEL : 0576- 86138372
FAX : 0576-86119106

Luoyang

Henan Luoyang
The Suzhou new generation of CNC Equipment
Co., Ltd. Luoyang Company
ADD : 1-1-704, Runsheng Building, Cross of Sanshan Road
and-Heluo Road, Hi-and-New Tech Park of Luoyang
TEL : 0379-65110352
FAX : 0379-65110352

Xuzhou

Syntec Technology (Suzhou) Co., Ltd. Xuzhou
Branch
ADD : Room -1503, Linghaibangonglounan, No. 66, Kungpeng
Road, Jingji Development Area, Xuzhou City, Jiangsu Province
TEL : 13656201020

Chongqing

Suzhou New Generation CNC Equipment Co., Ltd.
Chongqing Branch (CQST)
ADD : Block B, Dongli International, 11-6, Building 2, No. 62,
Taishan Boulevard East Section, Bu New District, Chongqing
City
TEL : 023-67913236
FAX : 023-67634382

Tianjin

The Suzhou new generation of CNC Equipment
Co., Ltd. Tianjin Branch
ADD : No. 37, A District, Huayuan, Qiaoruifeng, No. 7,
Waihuan West Road, Xiqing District, Tianjin City
TEL : 022-23739192-801
FAX : 022-23739192

Shandong

Shandong Jinan
Suzhou SYNTEC Equipment Co.,Ltd. Jinan
Branch
ADD : Flyover District of Ji nan three Bridge Street No. 28
Luneng Cambridge 9 Building 3 unit 101 room
TEL : 0531-85807208
FAX : 0531-85805708

Hubei

Hubei Wuhan
Suzhou new generation of CNC Equipment Co.,
Ltd. Wuhan Branch
ADD : Room 2003-2006, A Guanggogooji, No.456,
Luoyu East Road, Hongshan District , Wuhan, China
TEL : 027-87638876
FAX : 027-87204137

Liaoning

Shenyang
Suzhou new generation of CNC Equipment Co.,
Ltd. Wuhan Branch
ADD : 22-1, C61-, Diycheng, No. 1, 1Jia1, Qigong Street, Tiexi
District, Shenyang City, Liaoning Province
TEL : 18698806526

Jinan

Syntec Technology (Suzhou) Co., Ltd. Jinan
Branch
ADD : 502, Unit 3, Building 11, Kanggiao, Luneng, No. 28,
Sankongqiao Street, Tianqiao District, Jinan
TEL : 0531-85907208
FAX : 0531-85905708

SYNTEC
新代科技股份有限公司

SYNTEC Technology Co., Ltd.

No.25, Yanfa 2nd Rd., East Dist., Hsinchu City
300, Taiwan (R.O.C.)

☎ 886-3-6663553

☎ 886-3-6663505

✉ sales@syntecclub.com.tw

Suzhou SYNTEC Equipment Co.,Ltd.

No. 9th, Chun Hui Road, Suzhou Industrial Park,
Jiangsu Province

☎ 86-512-69008860

☎ 86-512-65246029

✉ service@syntecclub.com.cn



<http://www.syntecclub.com.tw>

SYNTEC WOODWORKING CONTROLLER

SYNTEC 60 Series
-Solution for Furniture Manufacturing

TRUSTED TECHNICAL SERVICE



SYNTEC WOOD Controller

Hardware

FC Controller



600-Series is 97.5

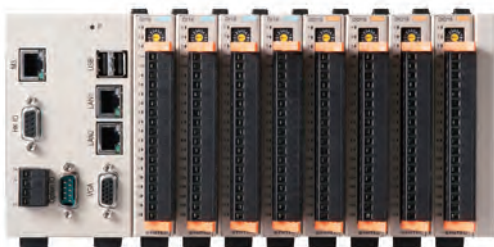
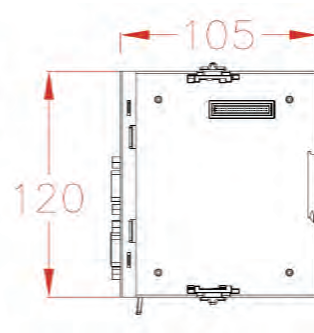
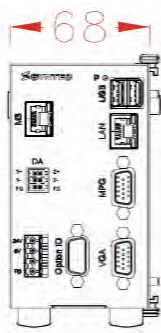

SRI - 16I/16O
Flexible IO

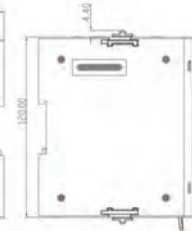
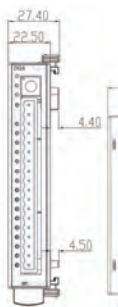

Mini All-in-one Driver (4 in 1)

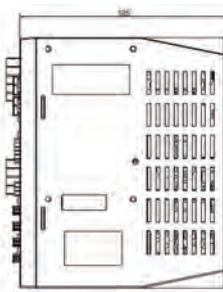
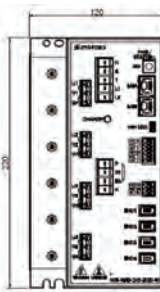

O:Standard △:Optional -: No *Not for sale in Taiwan Region

Unit: mm

Model	FC-60WA	FC-600WA	FC-60PA	* FC-60CB	* FC-60CA
Axes (Optional)	7 (16)	9 (18)	3 (18)	4(5)	4
DA	2	2	2	2	-
I/O	SRI flexible expansion IO module				
Servo Control	M3/ECAT				Pulse
VGA			1		1
Spindles	4	6	2	4	4
Storage	4GB	4GB	4GB	4GB	4GB
4Axes RTCP / RTCP	△ / -	△ / -	-	-	-
Wood CAD/CAM	△	△	-	-	-
PC Application	O	O	O	O	△

60PE Labeling Controller



10"
Touch Panel

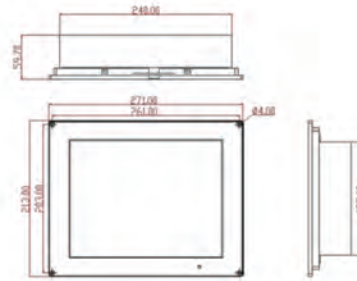

610-E5 Five-Axes Controller



Back-End
10" /15"
Standard Panel
Touch Panel



60W-E
Standard Panel
Controller

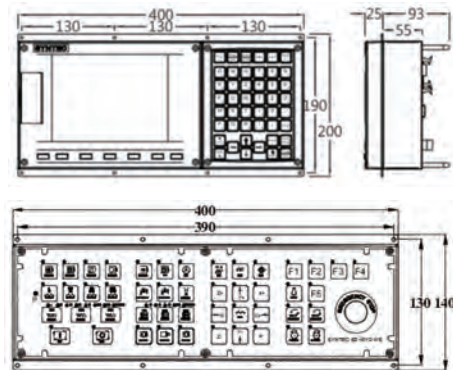

O:Standard △:Optional -: No *Not for sale in Taiwan Region

Model	60PE	*60W-E	610MA-E5	610WB-H	610WA-H
Axes (Optional)	4 (18)	4 (6)	8 (18)	12 (16)	8 (9)
DA	2	2	2	2	2
I/O	32/32	32/32	32/32	32/32	32/32
Servo Control	M3/ECAT			M2/M3/ECAT	
VGA	-	-	1	1	1
Spindles	0	4	6	6	6
Storage	4GB	4GB	4GB	4GB	4GB
4Axes RTCP / RTCP	-	△/ -	O / △	△/ -	△/ -
Wood CADCAM	-	-	-	△	△
PC Application	O	O	O	O	O

Single Machine Sol. Software Option

Auto Warehouse Tech.

Fully integrated by SYNTEC

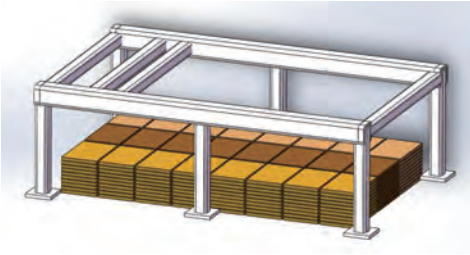

Load/Unload



Robot Cell



Easy UI to Set Program

Auto Label Machine



Process Sorting for high efficiency

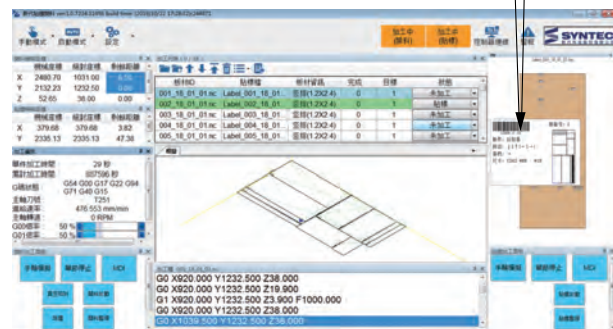

- Label/Router PC software
- Manual/Auto Label-Stick mode
- ZPL Industrial Printer Supported



Panel-Label Preview

Router/Saw

- **SYNTEC Servo**
All-in-one Package
- **Workinglist**
Auto Task-Arrange
- **CNC Nesting**
Optimize Panel Utilization Rate

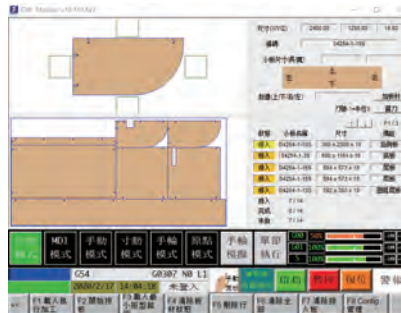

CNC Nesting



Print Labels



Working List



Boring Machine PC CAD/CAM Software

PC Boring Machine CAD/CAM:

- Support PTP, Six-Sided Boring..
- Support MPR, DXF, XML files import
- Support min. Panel to 100x50 Process

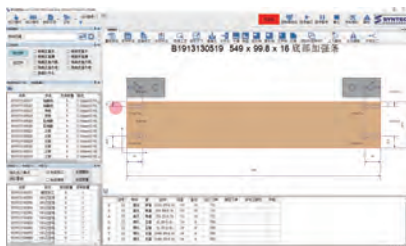

Modular UI

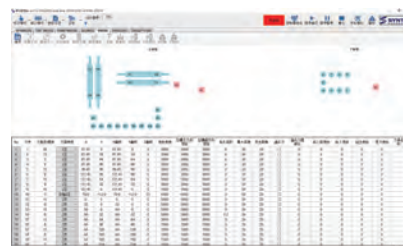

Visualization of Mechanism Parameters

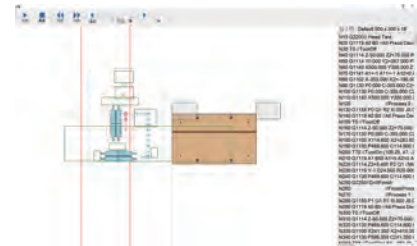

Animated Process Simulation

Flexible Manufacturing Cell

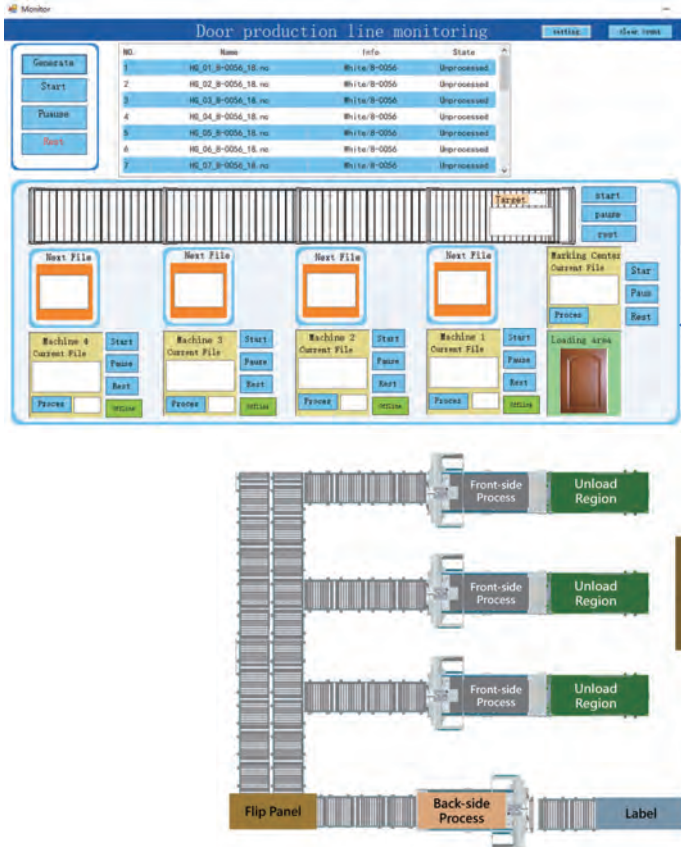

Door Production Line

- PC Software integrates Monitor/Data
- Connection/Manufacturing optimization in one station

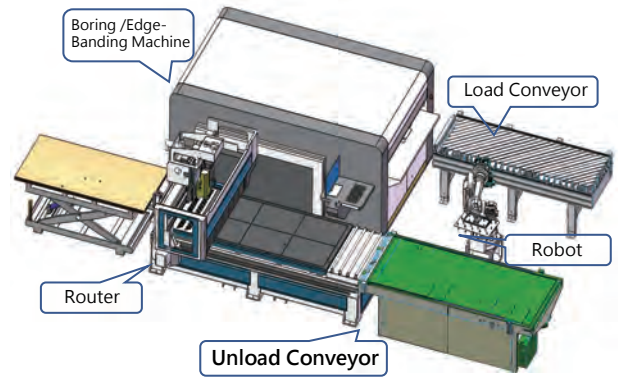

Robot Load/Unload Cell

Overall Manufacturing Integration

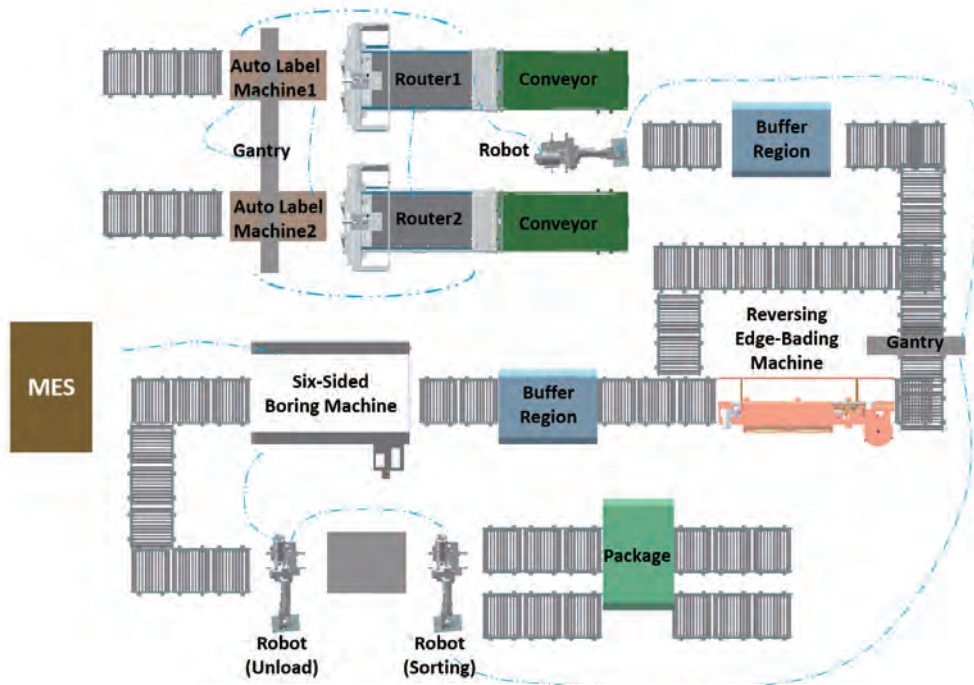

Total Solution for Panel Furniture Manufacturing

Five-Axes Control

Five-Axes Control for Surface Process

Support Several types correction

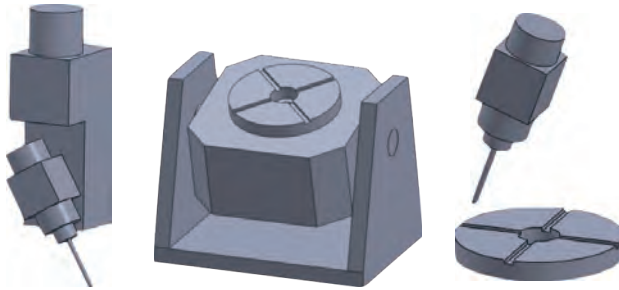

Tool Rotation Table Rotation Composite



Complete Hardware



Back-End
 10" / 15" Standard Panel / Touch Panel
 Suited for all manipulation demand

Rotation Tool Center Point Control (RTCP)



Support Multi-Chain RTCP

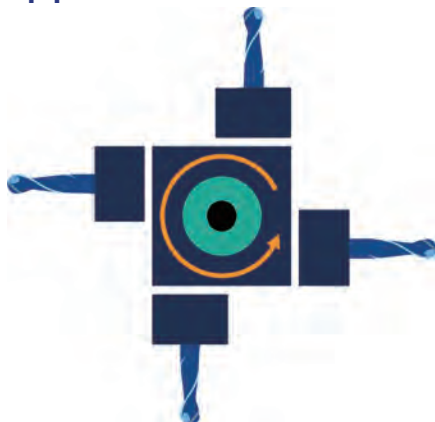

Cross-Type Multi-Head Spindle

Machine Tool Measurement

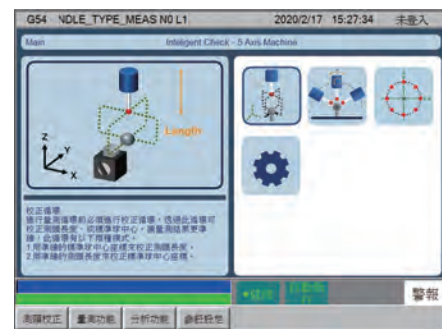

SYNTEC / HEXAGON / ISHIN

Model Specification

O:Standard △:Optional -: No *Not for sale in Taiwan Region

Model	FC-60WA	FC-600WA	FC-60PA	*FC-60CB	*FC-60CA
Servo Control	M3/ ECAT	M3/ ECAT	M3/ ECAT	M3/ ECAT	Pulse
Axes (Max)	7(16)	9(18)	3(18)	4	4
Axes Group	4	4	2	4	4
Max Synchronous Axes Control	4	4	4	4	4
RJ-45	1	1	1	1	1
VGA	1	1	1	1	1
RS-485	1	1	1	1	1
USB	2	2	2	2	2
PS/2	-	-	-	-	-
KB	-	-	-	-	-
HK	-	-	-	-	-
5V Output	-	-	-	-	-
OS	WinCE7	WinCE7	WinCE7	WinCE7	WinCE7
I/O	SRI	SRI	SRI	SRI	SRI
DA	2	2	2	2	-
Monitor	-	-	-	-	-
DiskC	256MB	4G	256MB	256MB	256MB
DiskA	4G	4G	4G	4G	4G
Option5-PC Application	O	O	O	O	△
Option12- RTCP	-	-	-	-	-
Option16 -Vision	△	△	-	△	△
Option27-Multi -5-Axes RTCP	-	-	-	-	-
Option29-4 AXRTCP	△	△	-	-	-
Option30- 5Axes linkage	-	△	-	-	-
Option32- ROT	△	△	-	△	-
Option36- WOOD CAM	△	△	-	-	-

Model Specification

O:Standard △:Optional -: No *Not for sale in Taiwan Region

Model	*60W-E	60PE	610WA-H	610WB-H	610MA-E5
Servo Control	M3/ ECAT	M3/ ECAT	M2/M3	M2/M3	M3/ ECAT
Axes (Max)	4(6)	4(18)	8(9)	12(16)	8(18)
Axes Group	4	2	4	4	4
Max Synchronous Axes Control	4	4	4	4	9
RJ-45	1	1	1	1	1
VGA	-	-	1	1	1
RS-485	1	1	1	1	1
USB	2	2	2	2	2
PS/2	O	O	-	-	-
KB	O	O	-	-	-
HK	O	O	-	-	-
5V Output	O	O	-	-	-
OS	WinCE7	WinCE7	WinCE7	WinCE7	WinCE7
I/O	32/32	32/32	32/32	32/32	32/32
DA	2	2	2	2	2
Monitor	8" Stand	10" Touch Panel	-	-	10" /15" Stand/Touch
DiskC	4G	4G	4G	4G	4G
DiskA	4G	4G	4G	4G	4G
Option5-PC Application	O	O	O	O	O
Option12- RTCP	-	-	-	-	△
Option16 -Vision	-	-	△	△	△
Option27-Multi -5-Axes RTCP	-	-	-	-	△
Option29-4 AXRTCP	△	-	△	△	O
Option30- 5Axes linkage	-	-	△	△	O
Option32- ROT	△	-	△	△	△
Option36- WOOD CAM	-	-	△	△	-

